



FlyForms International L.L.C.

Formwork Solutions ■ Supply ■ Design & Engineering
■ Technical Consultation ■ Training & Supervision



Vito-Wall Panel System

Assembly and Application Guide

Product Information & Features

Table Content

| | |
|------------------------------------------------|-------|
| Product Information & Features..... | 2 |
| Product Overview | 3 |
| Components | 4-10 |
| Panel Arrangement in Different Height..... | 11-13 |
| Application of Aligning Panel Clamp..... | 14 |
| Application of Adjustable Aligning Clamp | 15 |
| Application of Outer Corner Clamp..... | 16 |
| Vito Inner Corner Panel | 16 |
| T - Wall Connection | 17 |
| StoPend | 17 |
| Application of Hinged & Outer Corner 20 | 18 |
| Column Formwork With MP Panels..... | 19 |
| Column Formwork with Column Panels | 20 |
| Vito WalkWay Bracket | 21 |
| Formwork Strutting using Align Strut | 22 |
| Formwork Strutting using Steel Prop | 23 |
| Vito Shaft Formwork..... | 24-25 |
| Engineering, Design & Drawings..... | 26-27 |

Product Information

The following instructions for erection and use include detailed information on the handling and proper application of the products that are described and depicted. All instructions regarding technical operation and function have to be observed carefully. Exceptional use requires separate design calculation. With regard to safe and correct use of our products, all relevant safety, regulations and instructions of national institutes and/or local authorities have to be followed.

Damaged components have to be sorted out. In case of repairs, only original FFI spare parts must be used. Combined use of our formwork systems with equipment from other suppliers may involve certain dangers and, therefore, requires an additional checkup. For reasons of further technical development we emphatically reserve the right to revise, change or modify any of the product's components at any time without prior notice.

The Vito wall Panel System is designed and manufactured in accordance with BS EN 12812 : 2008, code of practice for Falsework

Product Features

The Vito formwork is a steel framed panel which is ready for use and very rugged.

The 2.70 m, 3.30 m and 1.20 m panels have various widths from 45 cm to 1.20 m and can be delivered in steps of 15 cm or 5 cm. Profitable giant panels are also available.

All Vito panels are based on sturdy 14 cm deep steel profiles for the edges. These edge profiles are prepared with a special shaping on the inside that allows application of the patented Vito connecting clamps.

Tie holes are provided in the vertical edge profiles. Exact alignment of the erected panel is made possible through the recess of the base edge profile by using a crow-bar (or nail-remover).

The 18 mm thick plywood sheet is supported by eight or ten intermediate bars of equal design. They also offer numerous possibilities for the attachment of Vito accessories.

The steel frame of the Vito panel is completely hot-dip galvanized.

All the panels can be combined in various ways, lying on their sides or standing upright. They can also be installed in a staggered arrangement as their interconnection is independent of any dimension modules.

A panel depth of 14 cm guarantees good load-bearing capacity (80 kN/m²)* so that for a single-storey formwork of 2.70 and 3.30 metres height, concrete pressure and rate of concrete placing need not be taken into consideration. The 18 mm thick plywood is glued 7-fold and coated with 350 g/m² phenol resin (on the concrete-sided surface). Because of this, a high number of applications and a long life span is guaranteed. The 10-fold steel frame support of the plywood (for a panel height of 2.70 m) reduces deflection and results in a smooth concrete finish.

The use of aligning panel clamps to connect two panels, accelerates shuttering work. The joints are made absolutely tight and the panels are aligned perfectly without any mismatching.

The aligning panel clamp also permits the repositioning of large-area formwork elements without having to install any additional stiffening walers. It can be used with the Vito ratchet or with a hammer. Use of the ratchet allows less fatiguing work from ground level (for single-storey formwork) and, moreover, spares the material.

Using the components included in the basic system, you will be able to solve formwork problems in industrial and housing construction.

The parts included in the additional components widen the application possibilities of formwork and simplify concreting. All Vito formwork steel parts are hot-dip galvanized.

Product Overview

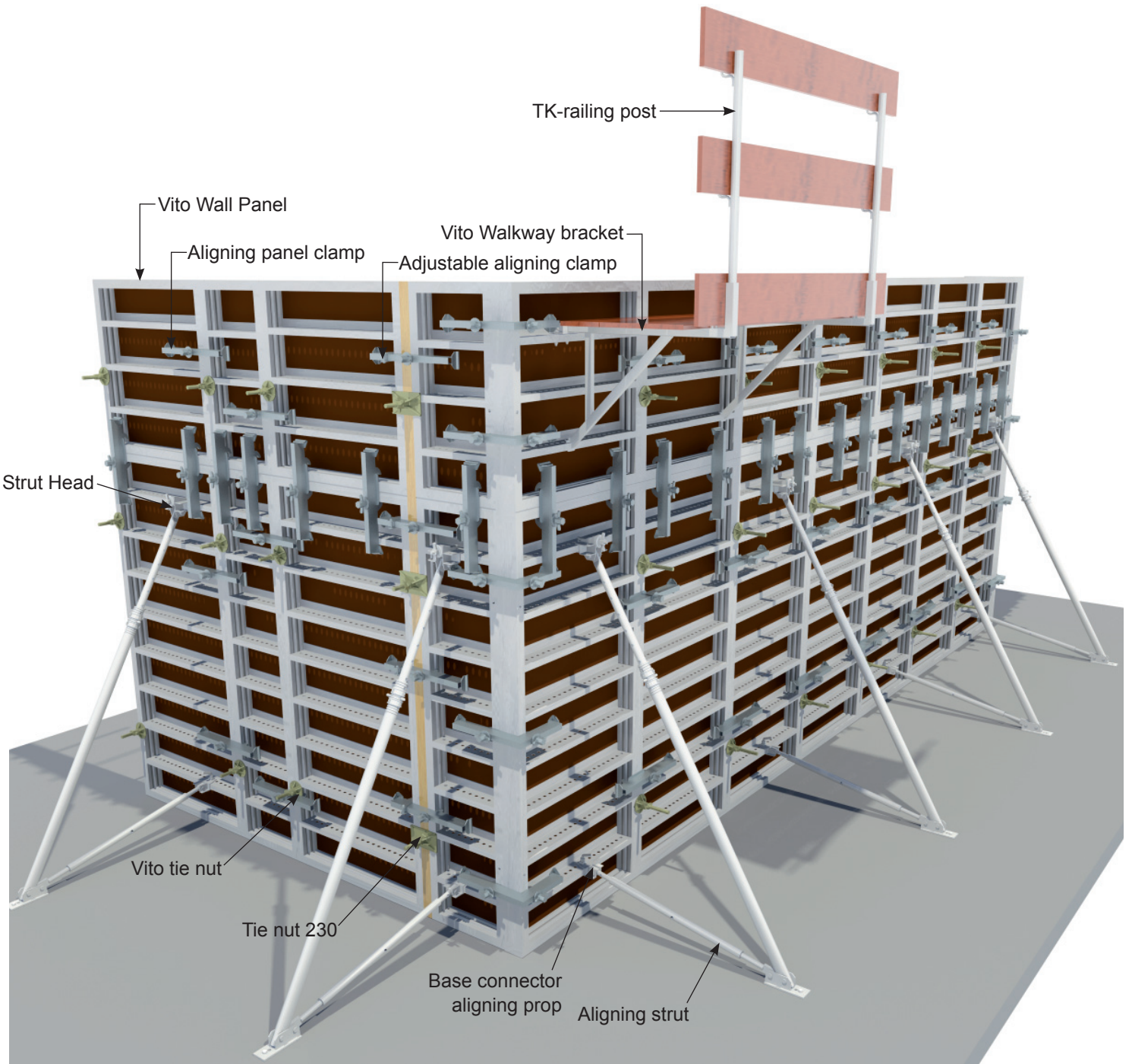

Components

| | | Art. No | Weight Kg/pc. |
|-----------------------------|------------------------|---------|------------------|
| Vito-Panel 120 x 330 | (3.96 m ²) | 110010 | 179.48 |
| Vito-Panel 105 x 330 | (3.47 m ²) | 110009 | 163.55 |
| Vito-Panel 90 x 330 | (2.97 m ²) | 110008 | 146.05 |
| Vito-Panel 75 x 330 | (2.48 m ²) | 110007 | 130.19 |
| Vito-Panel 70 x 330 | (2.31 m ²) | 110006 | 124.78 |
| Vito-Panel 65 x 330 | (2.15 m ²) | 110005 | 119.48 |
| Vito-Panel 60 x 330 | (1.98 m ²) | 110004 | 114.16 |
| Vito-Panel 55 x 330 | (1.82 m ²) | 110003 | 107.44 |
| Vito-Panel 45 x 330 | (1.49 m ²) | 110002 | 96.92 |
| Vito-Panel 30 x 330 | (0.99 m ²) | 110001 | 80.68 |

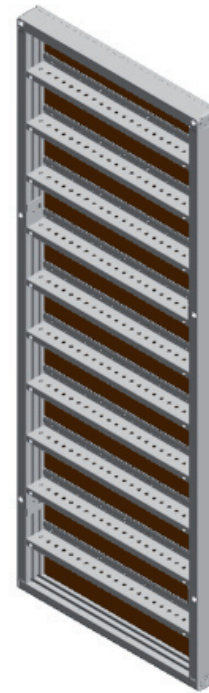



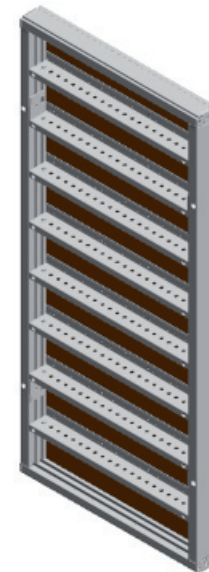

| | | | |
|-----------------------------|------------------------|--------|--------|
| Vito-Panel 120 x 270 | (3.24 m ²) | 110030 | 162.27 |
| Vito-Panel 105 x 270 | (2.84 m ²) | 110029 | 149.27 |
| Vito-Panel 90 x 270 | (2.43 m ²) | 110028 | 120.01 |
| Vito-Panel 75 x 270 | (2.03 m ²) | 110019 | 106.69 |
| Vito-Panel 70 x 270 | (1.89 m ²) | 110018 | 102.16 |
| Vito-Panel 65 x 270 | (1.76 m ²) | 110017 | 97.74 |
| Vito-Panel 60 x 270 | (1.62 m ²) | 110016 | 93.3 |
| Vito-Panel 55 x 270 | (1.49 m ²) | 110015 | 88.86 |
| Vito-Panel 45 x 270 | (1.22 m ²) | 110014 | 80.07 |
| Vito-Panel 30 x 270 | (0.81 m ²) | 110013 | 65.43 |

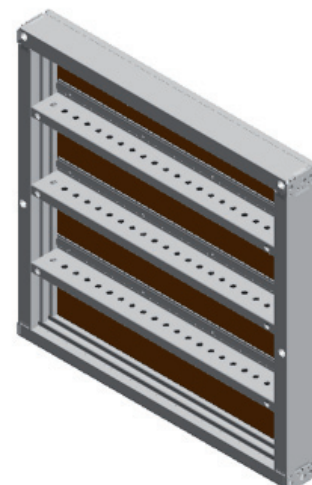

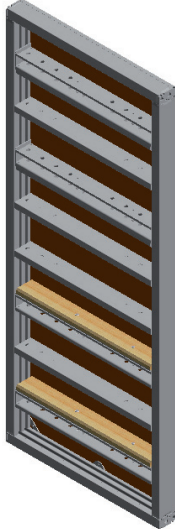

| | | | |
|-----------------------------|------------------------|--------|-------|
| Vito-Panel 120 x 120 | (1.44 m ²) | 110050 | 72.83 |
| Vito-Panel 105 x 120 | (1.26 m ²) | 110049 | 65.99 |
| Vito-Panel 90 x 120 | (1.08 m ²) | 110048 | 59.18 |
| Vito-Panel 75 x 120 | (0.90 m ²) | 110047 | 52.33 |
| Vito-Panel 70 x 120 | (0.84 m ²) | 110046 | 49.99 |
| Vito-Panel 65 x 120 | (0.78 m ²) | 110045 | 47.68 |
| Vito-Panel 60 x 120 | (0.72 m ²) | 110044 | 45.37 |
| Vito-Panel 55 x 120 | (0.66 m ²) | 110043 | 43.15 |
| Vito-Panel 45 x 120 | (0.54 m ²) | 110042 | 38.56 |
| Vito-Panel 30 x 120 | (0.36 m ²) | 110041 | 32.02 |



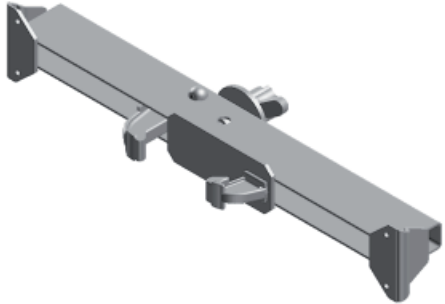
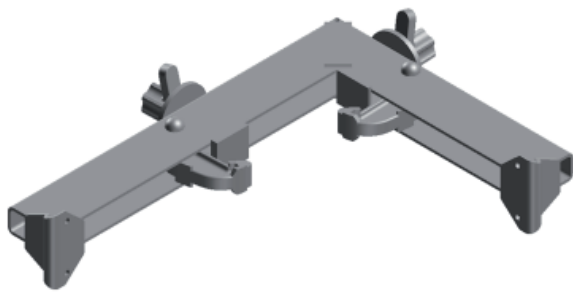
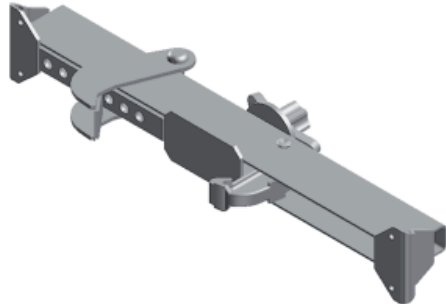

Components

| | | Art. No | Weight Kg/pc. | |
|----------------------------------|------------------------|---------|------------------|---------------------------------------------------------------------------------------|
| Column Frame 90x270 | (2.31 m ²) | 110319 | 160.60 |  |
| Column Frame 90x120 | (1.89 m ²) | 110320 | 68.40 | |
| Column Frame 90x60 | (0.84 m ²) | 110321 | 46.10 | |
| Vito-Inner corner 35/330 | (2.31 m ²) | 110111 | 113.66 |  |
| Vito-Inner corner 35/270 | (1.89 m ²) | 110112 | 94.27 | |
| Vito-Inner corner 35/120 | (0.84 m ²) | 110113 | 45.95 | |
| Vito-Hinged corner 35/330 | | 110121 | 135.12 |  |
| Vito-Hinged corner 35/270 | | 110122 | 111.66 | |
| Vito-Hinged corner 35/120 | | 110123 | 54.16 | |
| Vito-Outer corner 20/330 | | 110124 | 84.10 |  |
| Vito-Outer corner 20/270 | | 110125 | 69.30 | |
| Vito-Outer corner 20/120 | | 110126 | 31.40 | |



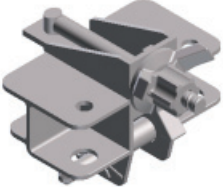
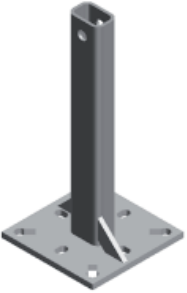
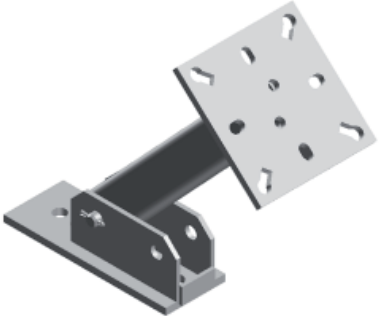

Components

| | Art. No | Weight Kg/pc. | |
|-----------------------------------------------------------------------------------------------------------------------------------------------------------------------------------|---------|---------------|--------------------------------------------------------------------------------------|
| <p>Aligning panel clamp For horizontally and vertically connecting the Vito panels.</p> | 110181 | 5.50 |  |
| <p>Outer corner clamp The corner clamp connects two standard panels to one outer corner</p> | 110182 | 8.80 |  |
| <p>Adjustable aligning clamp For horizontally and vertically connecting the Vito panels., but with additional adjustment area for adjustment widths of up to 15 cm</p> | 110183 | 6.00 |  |
| <p>Aligning strut Used together with the strut connector for exact alignment of the formwork.</p> | 110220 | 22.30 |  |



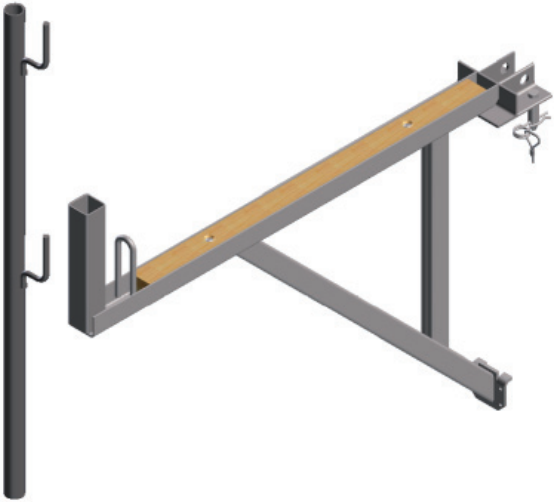

Components

| | Art. No | Weight Kg/pc. | |
|----------------------------------------------------------------------------------------------------------------------------------------------------------------------------------------------|---------|---------------|---------------------------------------------------------------------------------------|
| <p>Strut connector Used for connecting aligning struts</p> | 110219 | 8.90 |  |
| <p>Strut head Applicable to formwork heights $H < 3,90$ m. Used for connecting the strut adaptor or the wall strut</p> | 110223 | 4.33 |  |
| <p>Strut adaptor Used for Europlus props and other attachments of raking props</p> | 110221 | 4.88 |  |
| <p>Strut base Standard tubular steel props can simply be completed for supporting and aligning Vito formwork by using the above mentioned parts Connecting to the prop plate.</p> | 110222 | 7.70 |  |
| <p>Bolt and nut M12 x 30 For Connecting the strut adaptor and the strut base to the prop plate</p> | 110224 | 0.06 |  |

Components

| | Art. No | Weight Kg/pc. | |
|--------------------------------------------------------------------------------------------------------------------------------------------------------------------------------------------------------------------------------------------------------------|------------------|---------------|--------------------------------------------------------------------------------------|
| <p>BKS strut connector To connect BKS-props at all shuttering heights from prop lengths 8.0 m and longer (max. load 34 kN). For each connection 2 bolts and nuts M20 x 40 1 bolt and nut M 20 x 80 are required</p> | 110225 | 9.10 |  |
| <p>Base Connector align prop</p> | 110226 | 4.33 |  |
| <p>Vito-walkway bracket 90 TK-railing post</p> | 110211 110213 | 12.97 4.50 |  |
| <p>Waler bold D 20 for connecting the walkway bracket</p> <p>Spring pin Secures the bolt D 20</p> | 110331 110361 | 0.32 0.01 |  |

Components

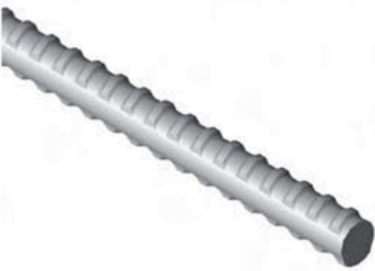
| | Art. No | Weight Kg/pc. | |
|---------------------------------------------------------------------------------------------------------------------------------|--------------------------------------|------------------------------|---------------------------------------------------------------------------------------|
| Vito tie nut (DW 15) | 110241 | 1.26 |  |
| Tie nut 230 (DW 15) | 110242 | 2.40 |  |
| Tie nut 150 (DW 20) | 110252 | 1.51 |  |
| Waler spanner (30 cm) Waler spanner L (50 cm) Tension nut (DW 15) To fasten the walers and panel. | 110152 110153 110154 | 0.76 1.07 0.65 |  |
| Tie rod 75 (DW 15) Tie rod 100 (DW 15) Tie rod 130 (DW 15) Tie rod 175 (DW 15) | 110246 110247 110248 110249 | 1.08 1.44 1.87 2.52 |  |
| Tie rod 20/100 (DW 15) Tie rod 20/130 (DW 15) | 110255 110256 | 2.56 3.33 | |
| S-bolt For connecting column frames only | 110322 | 1.90 | |

Components

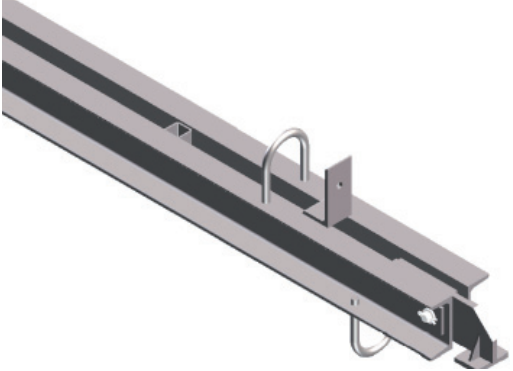
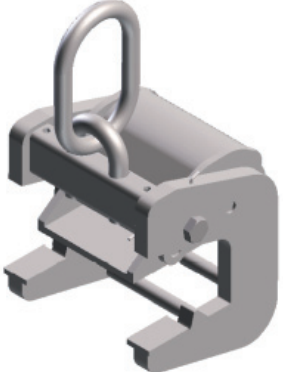
| | Art. No | Weight Kg/pc. | |
|------------------------------|---------|---------------|---------------------------------------------------------------------------------------|
| Box-out | 110288 | 2.60 |  |
| Platform beam 125-150 | 110287 | 55.00 |  |
| Platform beam 150-200 | 110286 | 68.60 | |
| Platform beam 200-250 | 110285 | 82.00 | |
| Platform beam 250-300 | 110284 | 95.40 | |
| Platform beam 300-350 | 110283 | 108.00 | |
| Platform beam 350-400 | 110282 | 122.20 | |
| Vito Crane adaptor | 110316 | 1.51 |  |
| | | | |

Panel Arrangement in Different Height

The Vito formwork panels are connected with the used of V-aligning panel clamp.

This connector creates tension-resistant, tight and aligned joints between formwork elements.

It can be used both on vertical panel joints and on horizontal joints on height-extended formwork.

Vito ratchet is required for tightening and loosing vito connectors.

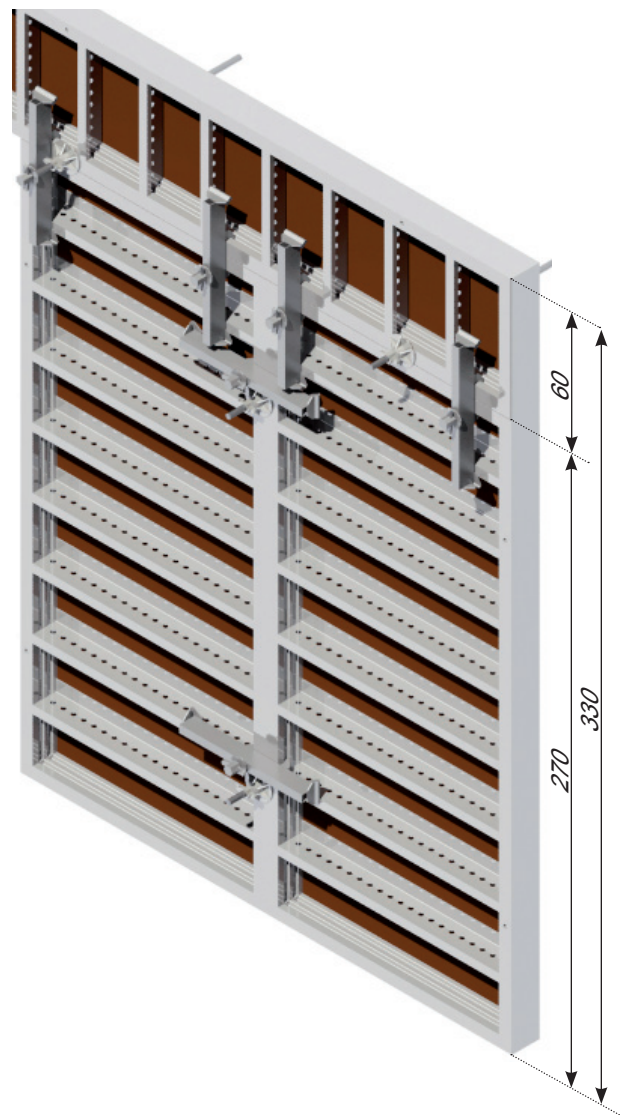
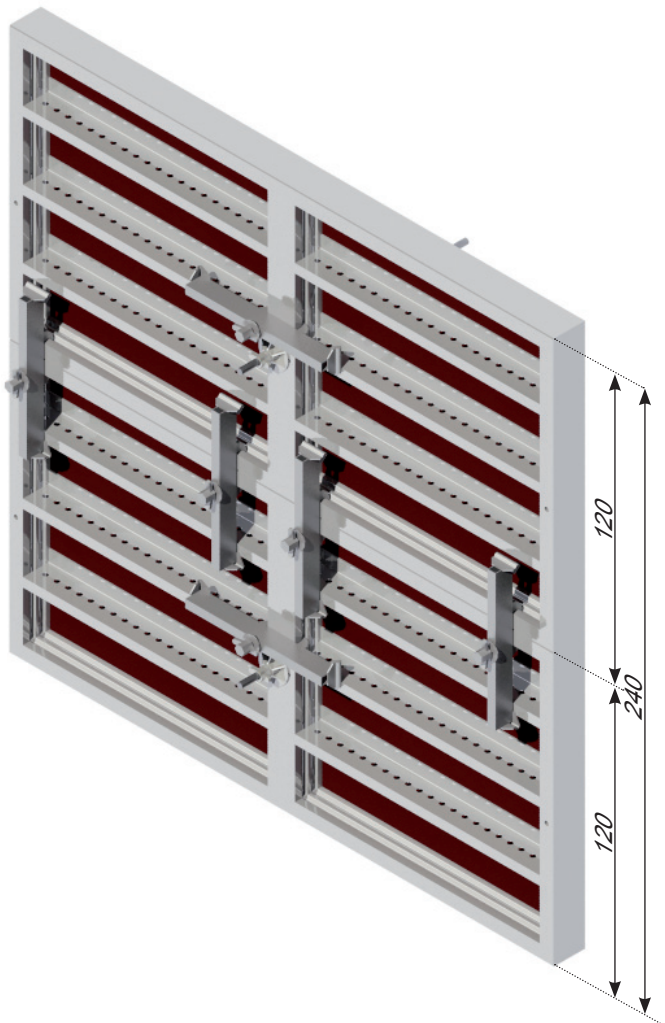
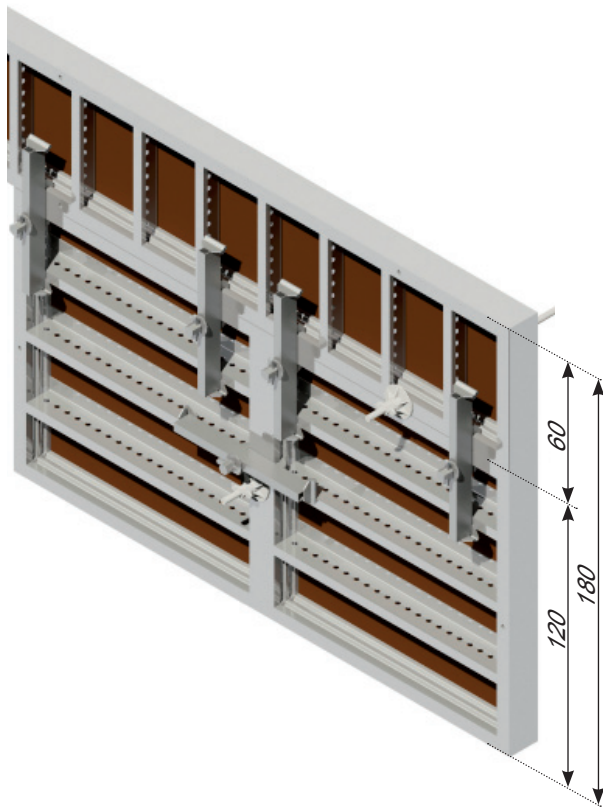

Panel Arrangement in Different Height

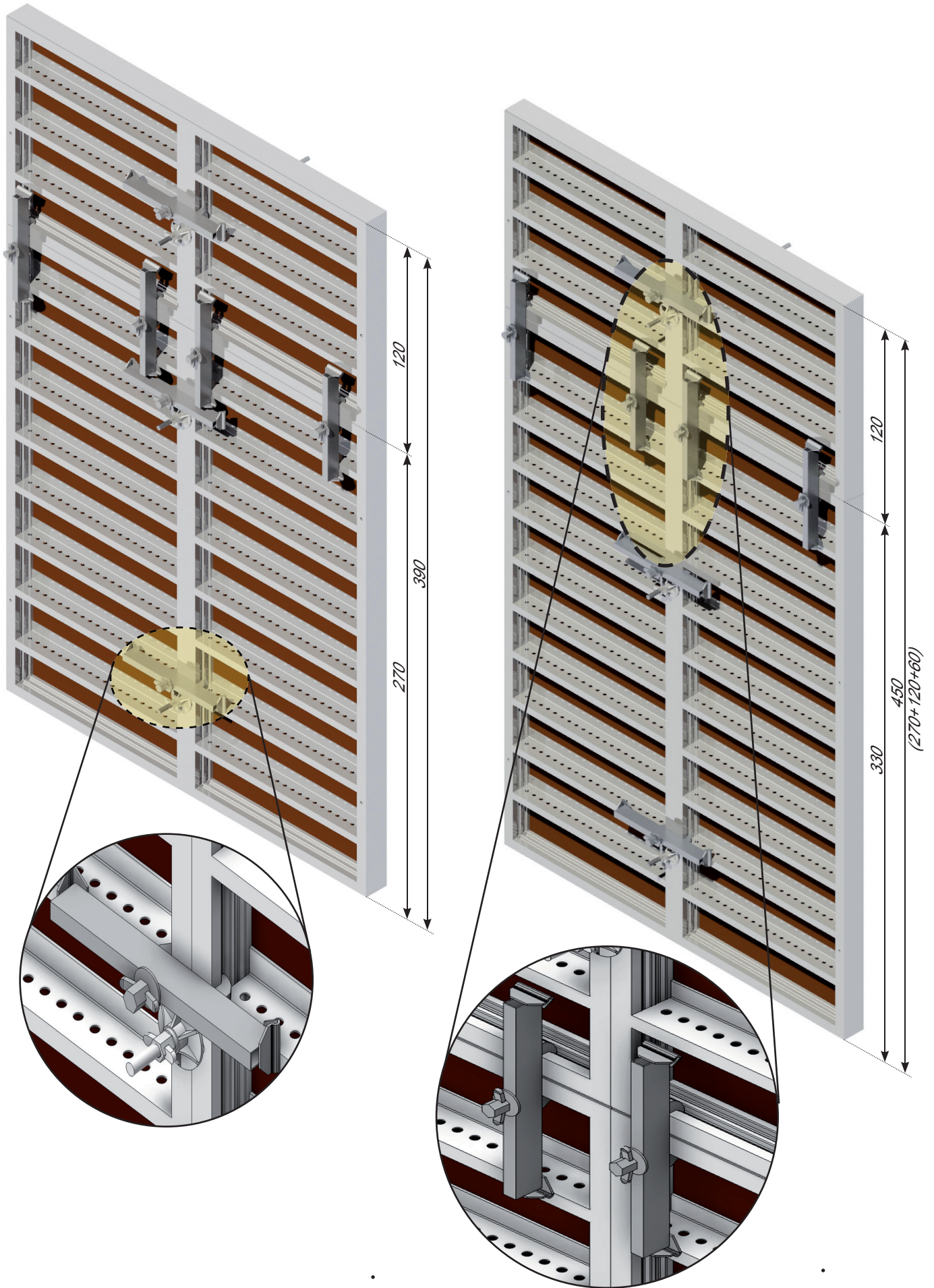

Panel Arrangement in Different Height

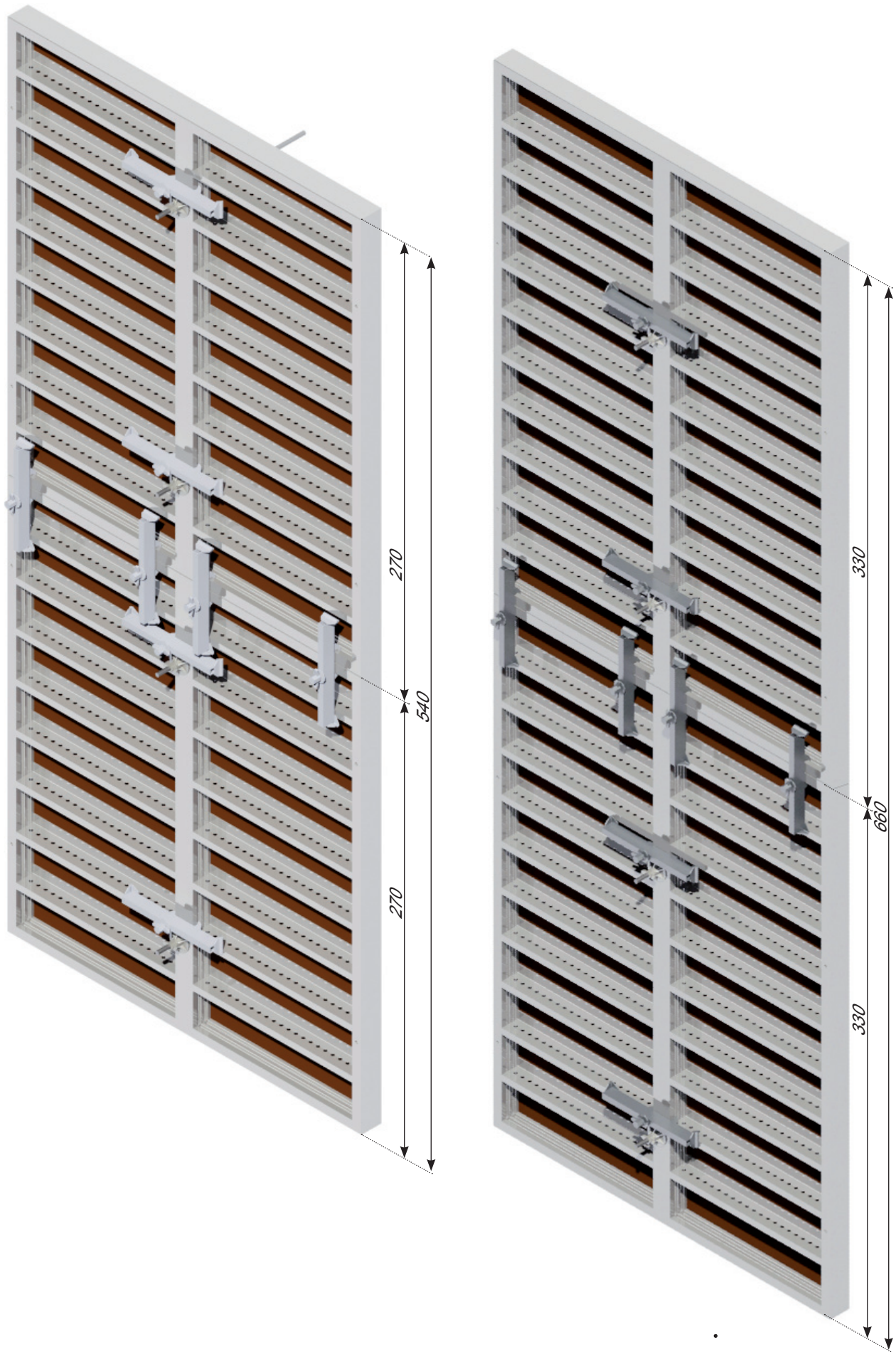

Application of Aligning Panel Clamp

The aligning panel clamp

Vito aligning panel clamp is used to join Vito panels horizontally and vertically regardless whether the panels are positioned standing, lying or staggered at height. The aligning panel clamp with its more than 63 cm long aligning profile provides an absolutely tight, flush-mounted and aligned panel joint.

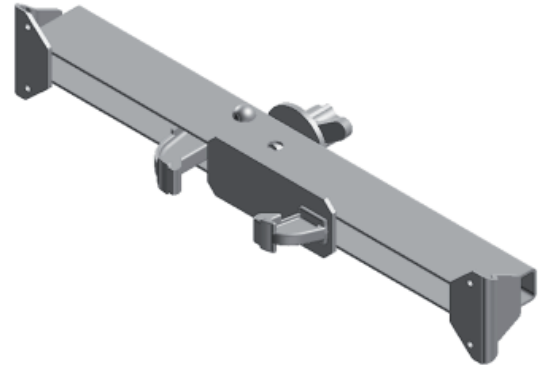

Vito formwork is tied via the tie holes provided in the panels. Plug must be removed before inserting the tierod. Unused tie holes should be sealed with plugs.

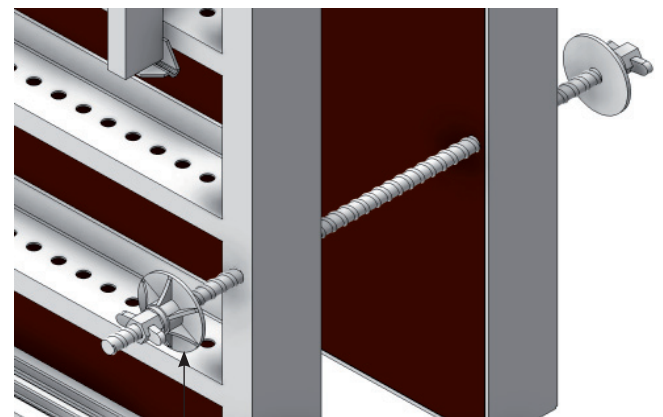
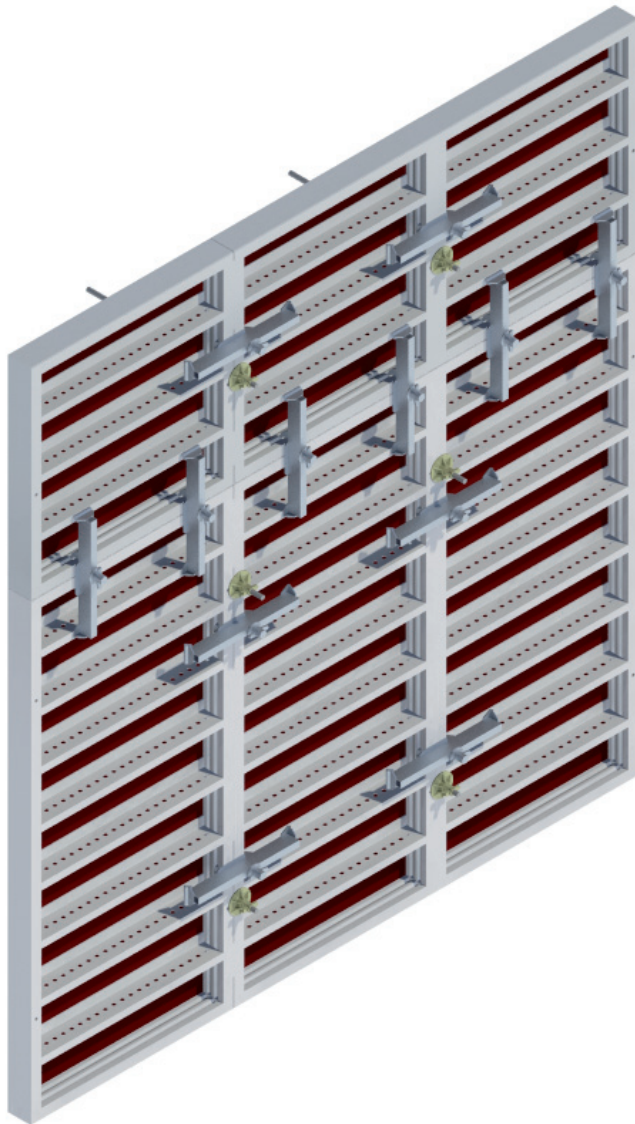

Vito tie nut

When tying the panel joint, the tie plate (13 cm dia) of the Vito tie nut extends across sufficiently to the neighbouring panel.

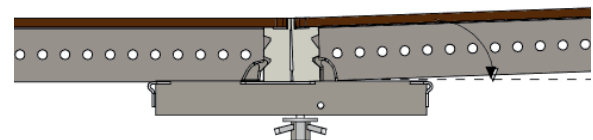

Slide **aligning panel clamp** onto the roughly aligned panels.

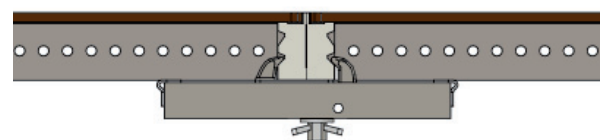

Tightening the toggle nut closes the joint and aligns the panels.

At a vertical panel joint with single-storey formwork both aligning panel clamps can be conveniently operated from ground level.

The use of the Vito ratchet makes the job fast, noiseless and easy on the components. No need to overtighten the toggle nut.

Application of Adjustable Aligning Clamp

The adjustable aligning clamp

The adjustable aligning clamp connects Vito panels in the same way and perfection as the aligning panel clamp does. Moreover, its sliding claw permits a stepless length adjustment with Timber at the panel joint of 0 to 15 cm.

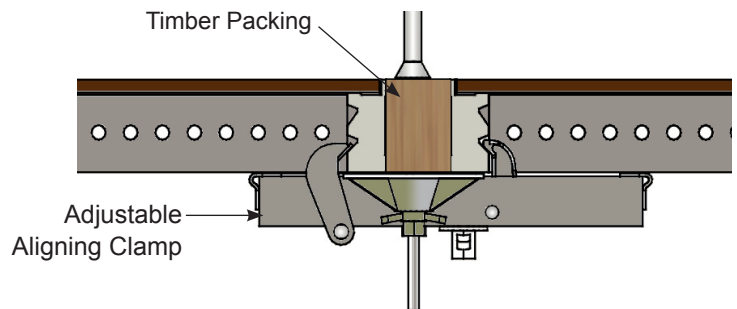
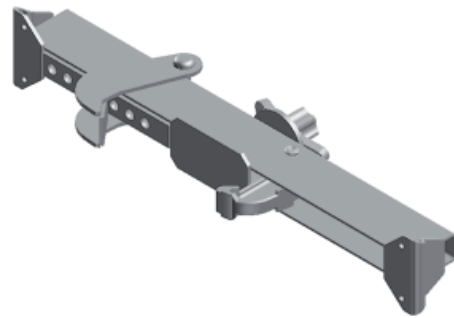

For an adjustment width of up to 10 cm the adjustment is used for tying purposes. Use large tie nut (e.g. tie nut 230) for this. For larger adjustments of 15cm both adjacent panels must be tied.

Adj. more than 15 cm

Length adjustments from 15 to 30 cm are shuttered by means of the vito waler is fastened at the panels profiles with 2 waler spanners each for an aligned, high tensile adjustments

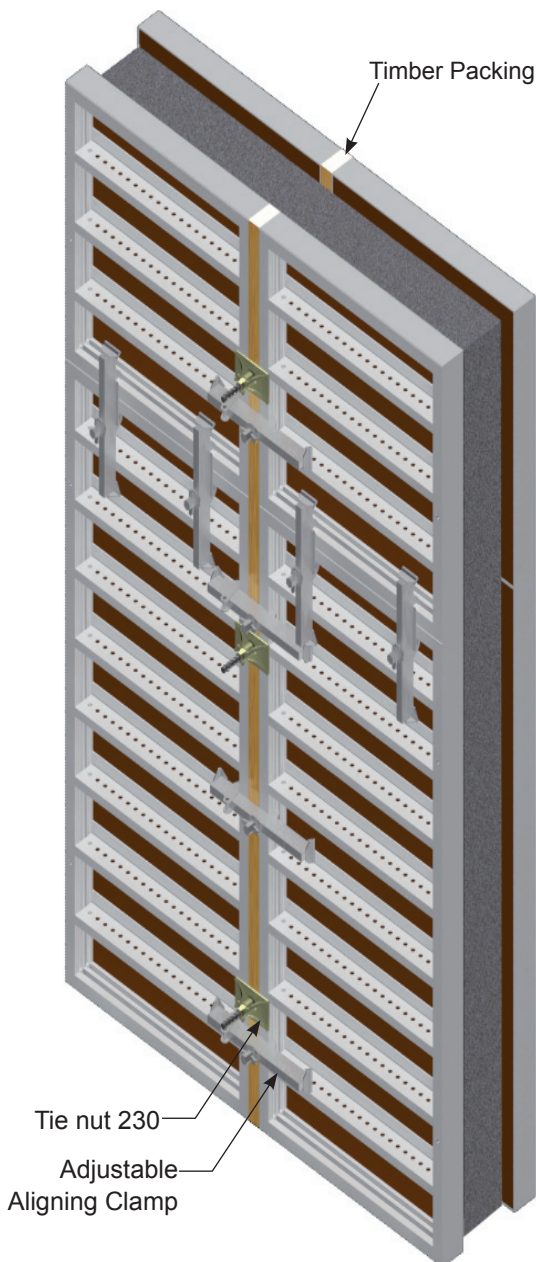
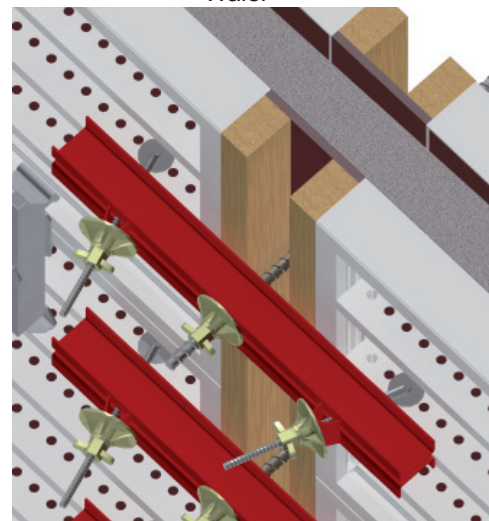
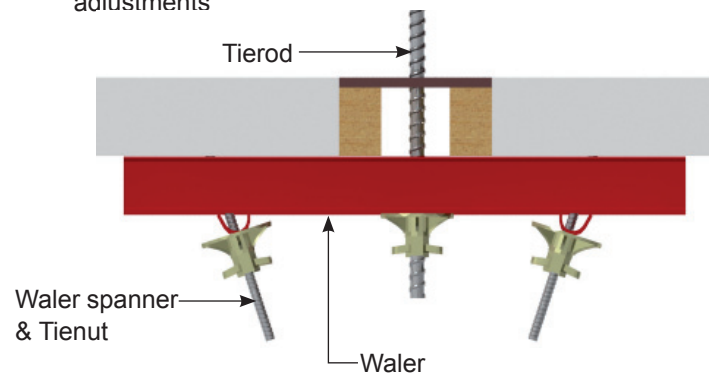

Note:

Adjustable aligning clamp (install **three adjustable aligning clamps** on 3.30 m high panels).

Outer Corner Clamp

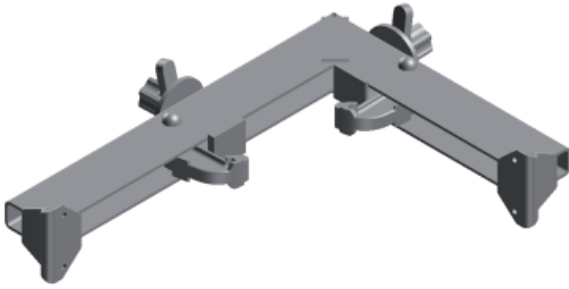

The right-angled outer corner is always composed of two Vito panels aligned and held together with outer corner clamps. The formwork can be adapted to wall thickness with the available elements of 30 to 90 cm and the 5 cm adjustment piece.

The number and arrangement of outer corner clamps and of the Vito clamps on the first joint of the outer corner depends on the thickness and height of the wall being shuttered

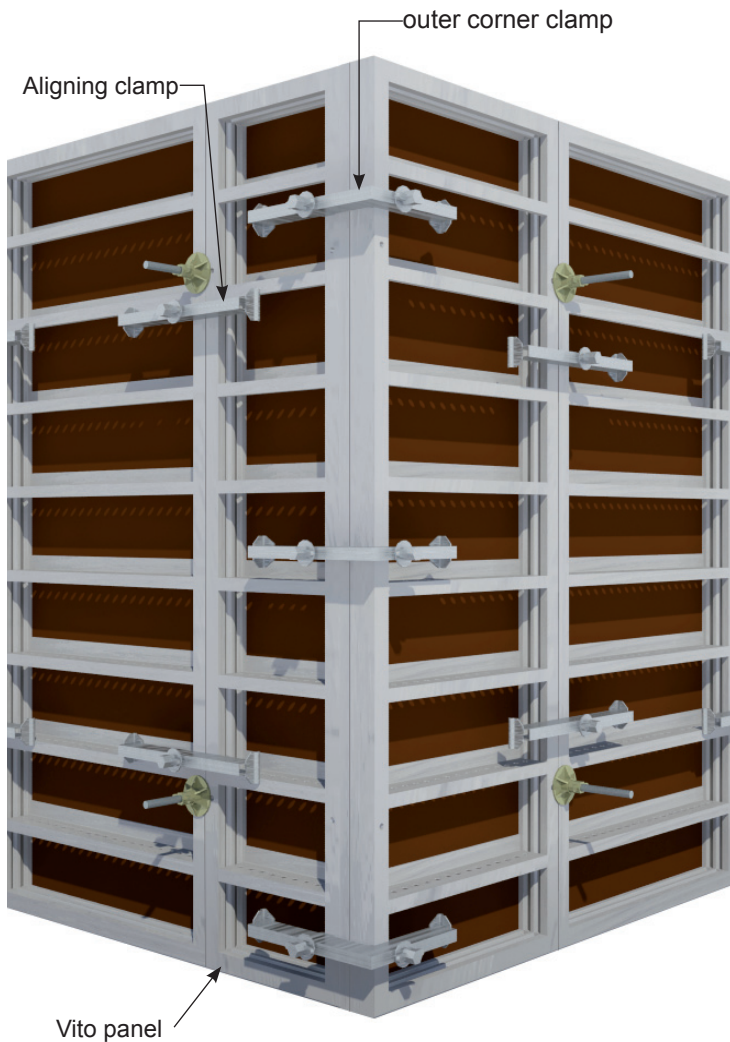

Inner Corner Panel

90° wall corners and T-walls are shuttered by means of the Vito inner corners. Adjustment to the desired wall thickness is carried out at the outer corners, which consist of standard panels and outer corner clamps.

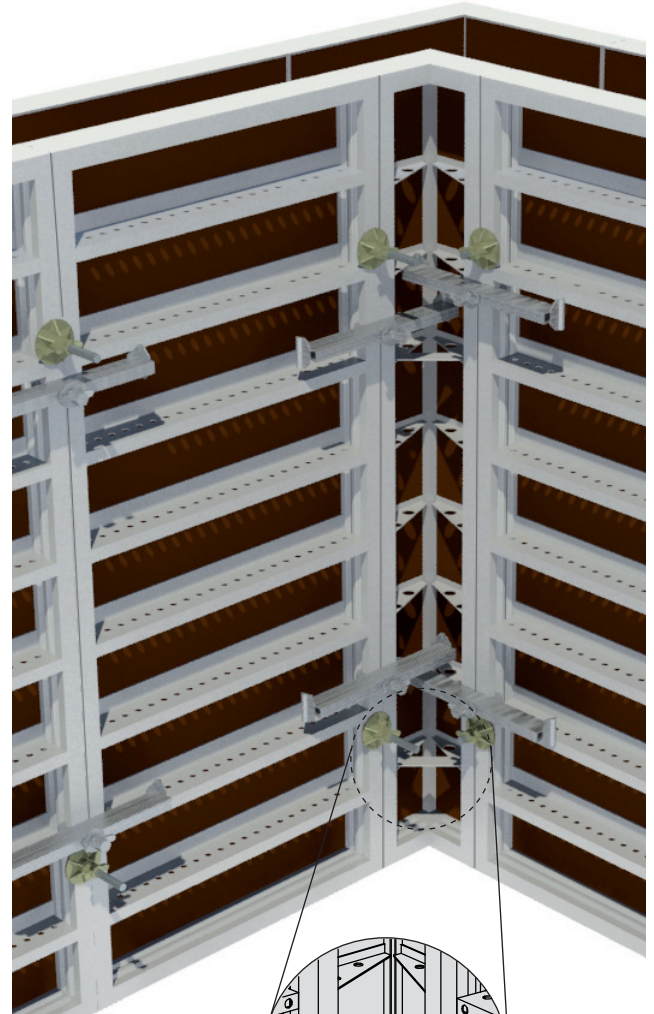

The possibility of reducing the 90° corner angle by about 2° assures easy and material-saving shuttering work.

At wall T-junctions, system shuttering can be simply used up to a wall thickness of 40 cm. Adaptation is possible with the various panel widths and the 5 cm wide corner adjustment piece.

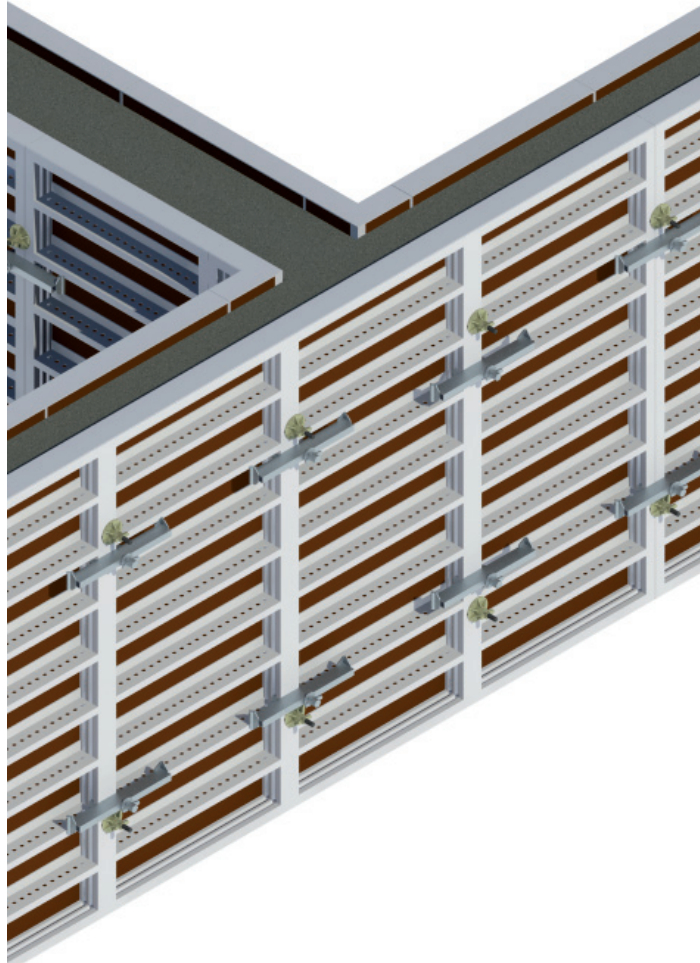

The Vito waler is also used for shuttering a bulkhead. It is fastened with two waler spanners to the last Vito panels, which are tied in the usual manner.

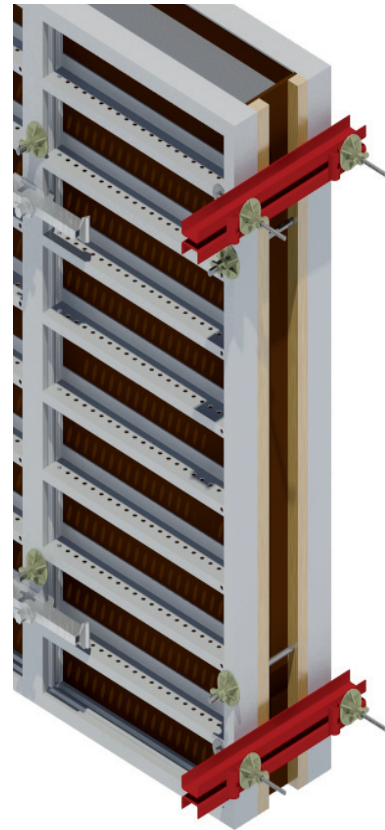

Stopends can also be formed with the Vito formwork by using the **outer corner clamps**. The maximum wall thickness is then **limited to 30 cm**. The corner clamps are to be assembled in the illustrated manner and quantity on the final panels.

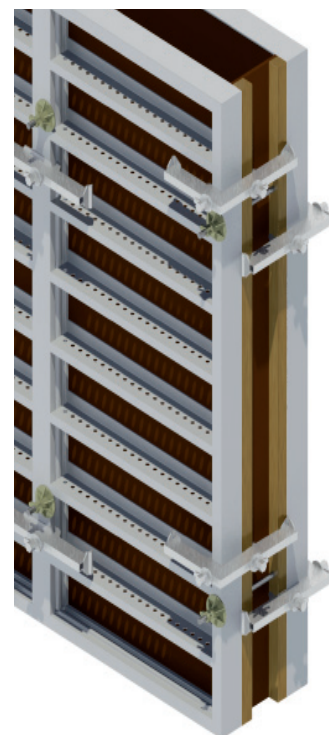
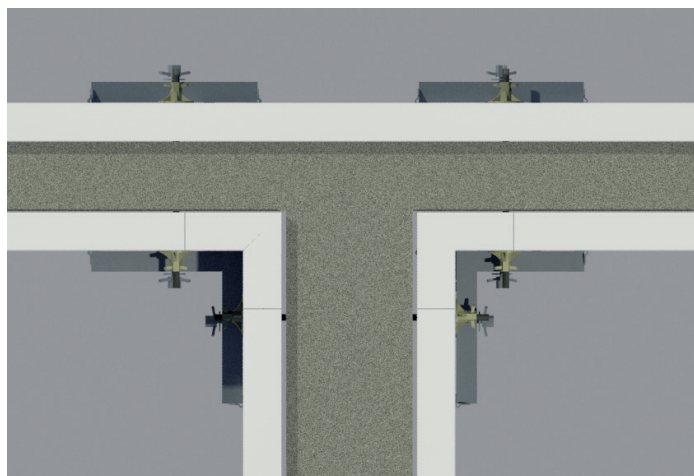

Application of Hinged & Outer Corner 20

Non-rectangular corners can simply be shuttered with hinged corners and the outer corners 20. The adjustment range of these components permits oblique angular corners from 60° to 175°. Adjusting members compensate for differing wall thicknesses.

Adjustment ranges for the hinged corner and the outer corner 20:

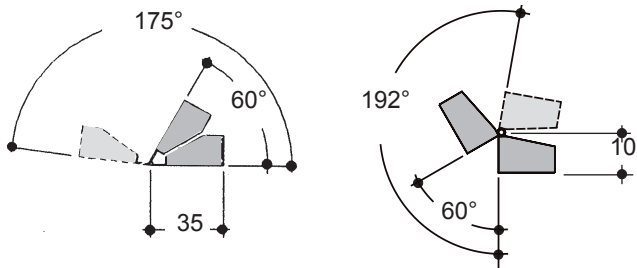

Obtuse angled corner

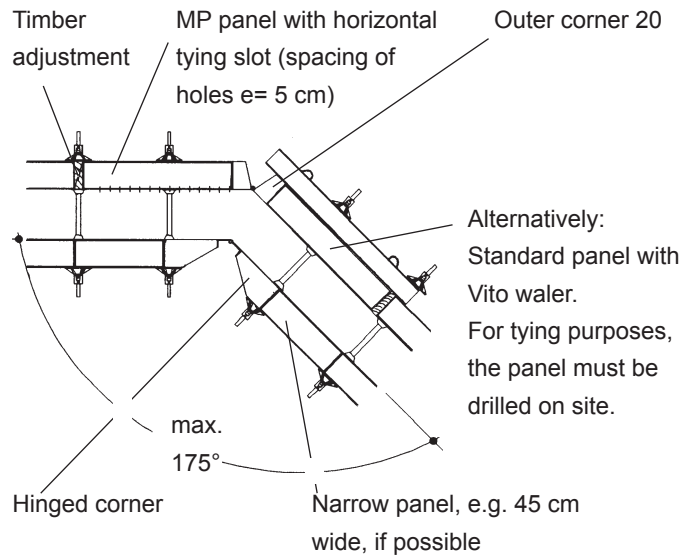

Acute angled corner

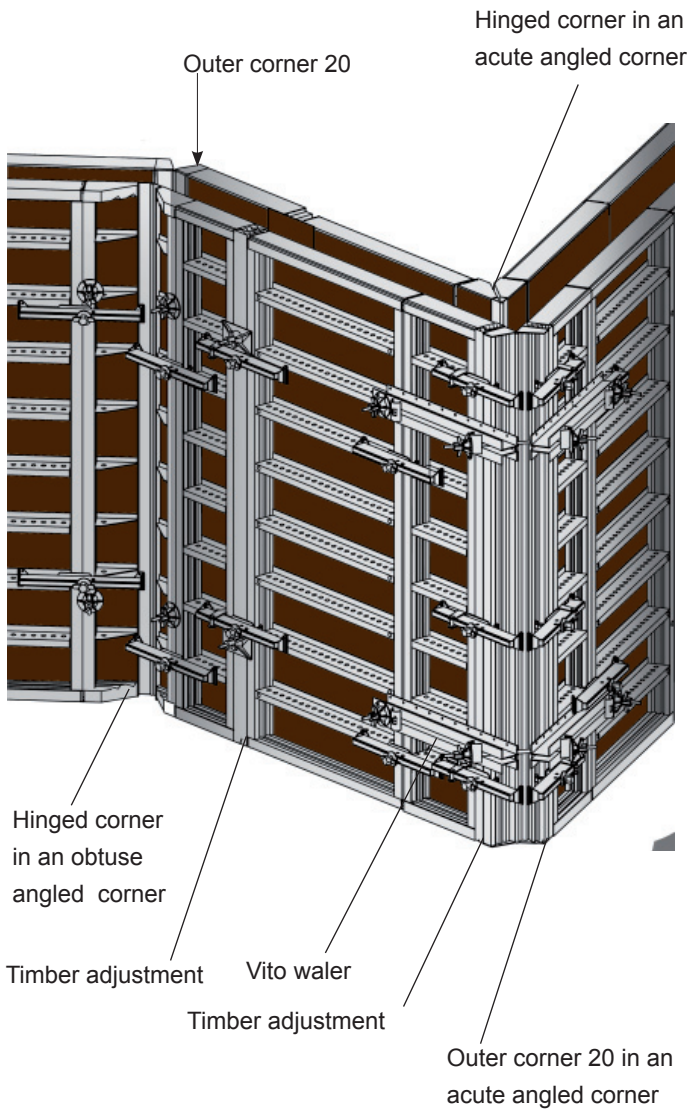
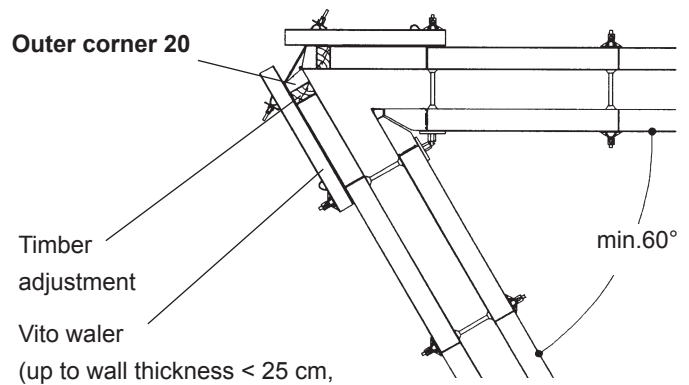

Column Formwork With MP Panels

(Permissible concrete pressure = 80 kN/m²)
 With their holes in 5 cm increments and the transverse hole in the edge profile, these panels are highly suitable for shuttering columns with square and rectangular cross-sections.

Four different MP panel lengths provide a height adjustment in 30 cm increments.

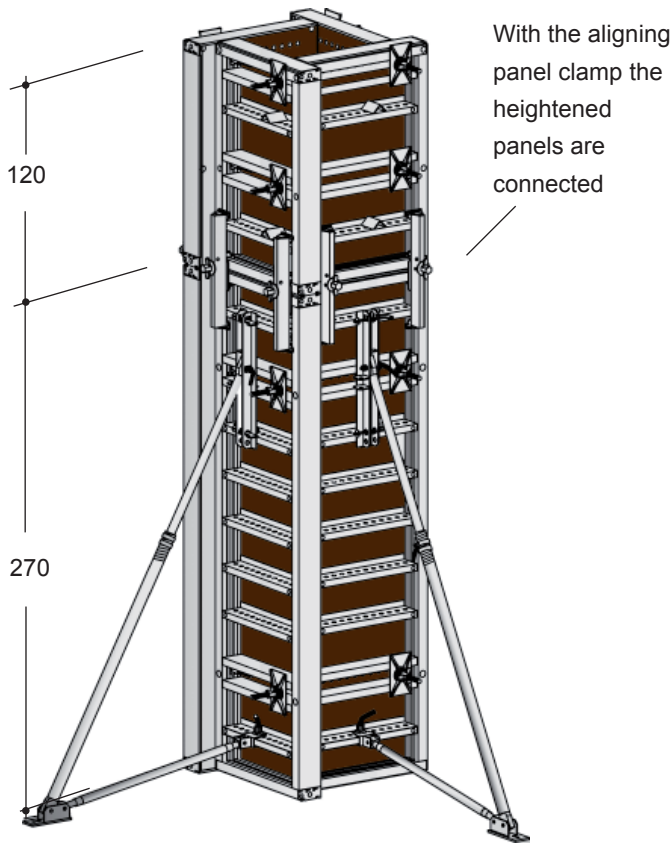

The panels are connected by means of the MP-bolt, the MP-nut and the tie nut 230. For shuttering heights of up to 2.70 m, only two spanning elements are required. Max. column cross section: 60 x 60 cm.

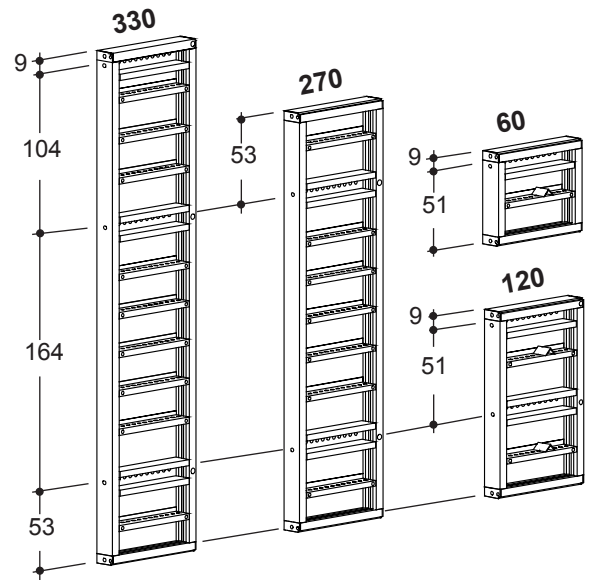
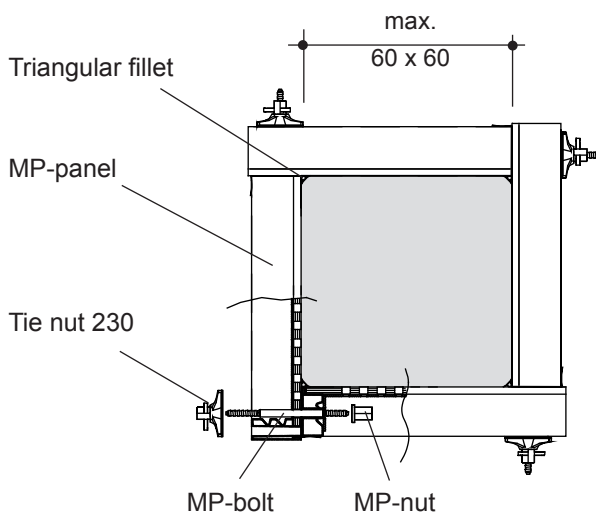

The spacing of the holes of the MP-panels

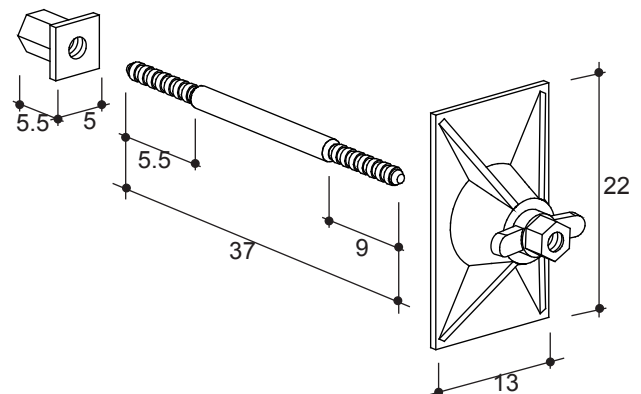
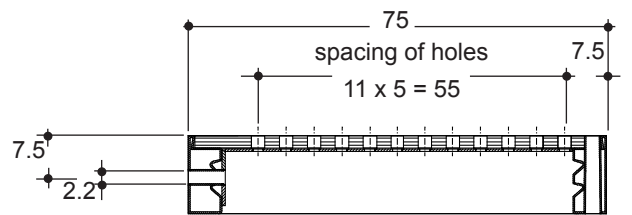

With additional ties and with further **MP-panels**, larger column cross-sections can be shuttered, too.

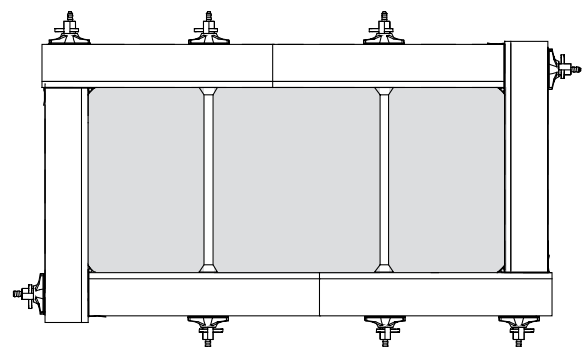

Column Formwork with Column Panels

(permissible concrete pressure = 100 kN/m²)

A special column formwork for cross sections of up to 90 x 90 cm and an extremely high permissible concrete pressure. The column frames are supplied without shuttering skin. They can simply be covered (by means of the built-in wooden lath) on-site with an appropriate shuttering skin in the desired manner.

FFI also supplies shuttering skins in cut-to-size shape, with or without pre-drilled segment holes.

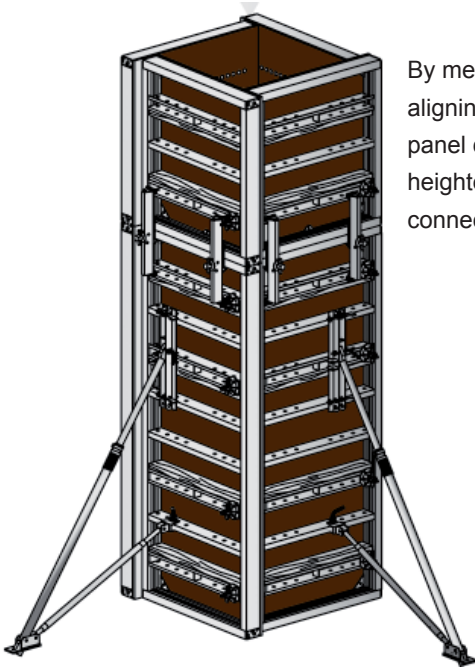

By means of the aligning panel clamp the heightened panels are connected.

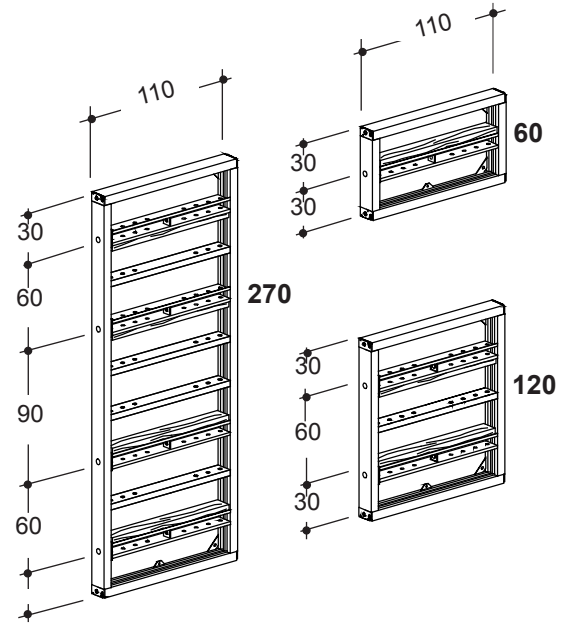

The hole increments of the column frames:

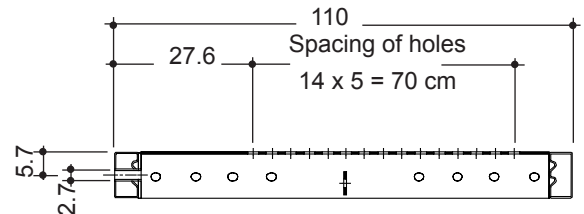

For each **S-bolt** a **Vito tie nut** is required.

A 2.70 m high column formwork requires 16, a 1.20 m heightening 8 and a 0.60 m heightening 4 **S-bolts** with **Vito tie nuts**.

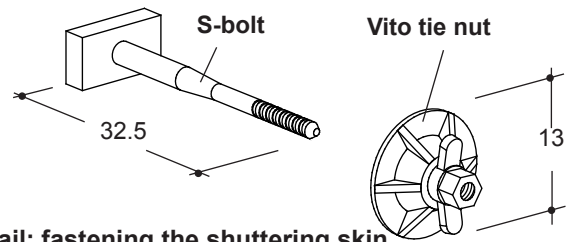

Detail: fastening the shuttering skin

The shuttering skin can be screwed or nailed onto the nailable lath or screwed from the rear through the tying profile. Moreover, at the top and lower edge profile of the column frames fasteners are provided.

The frames must be connected as illustrated with the **S-bolts** and one **Vito tie nut** each after the shuttering skin has been attached.

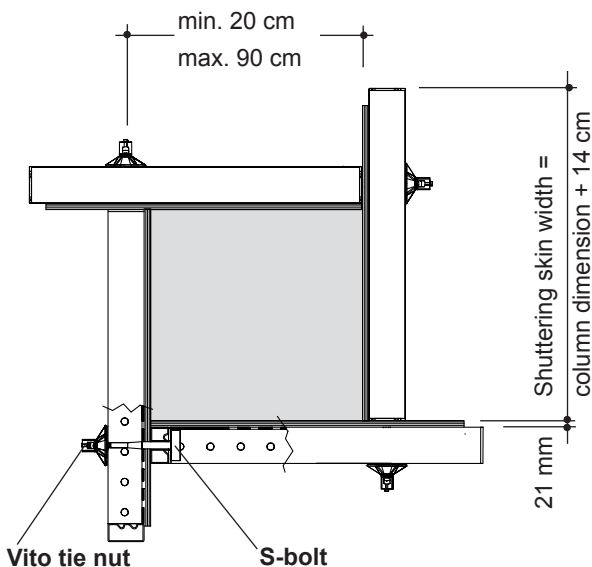

Shuttering skin 21 mm

Plywood screw or screw nail 6 x 60

The 28 dia. plug closes the unused holes

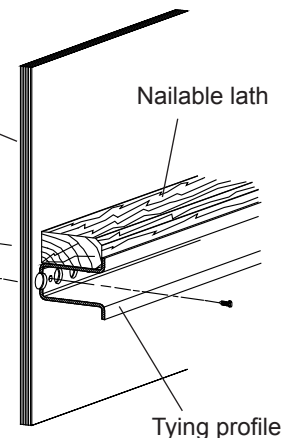

Vito WalkWay Bracket

The stage for concreting is formed with the Vito-walkway bracket and the inserted TK-railing post. Simply hang the brackets with their receiving pins into the hole segment of the transverse ribs of the panels. Fastening with the unlosably attached spring pin secures the walkway bracket. The distances between the Vito-walkway brackets (freely selectable in 5 cm increments) must not exceed 2.50 m* at a permissible load of 1.5 kN/m². The planks can be nailed to the wooden lath built into the bracket's horizontal member.

*For applications over ground level from 31.5 m - 100 m, the maximum distance is limited to 1.90 m.

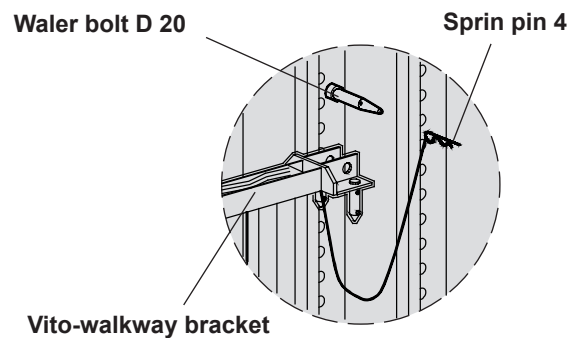
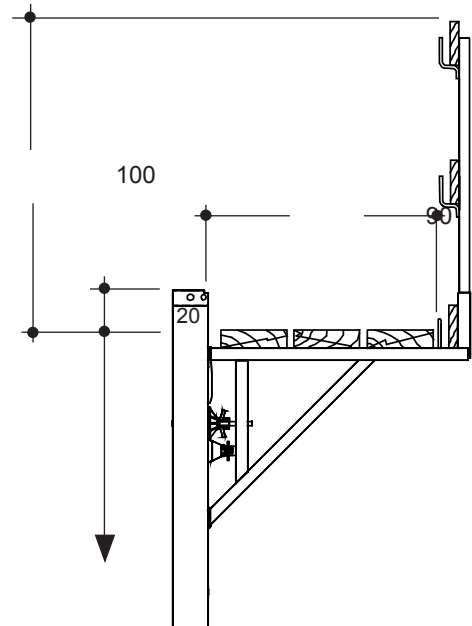
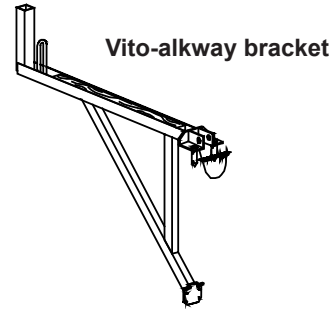
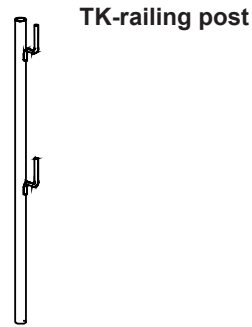
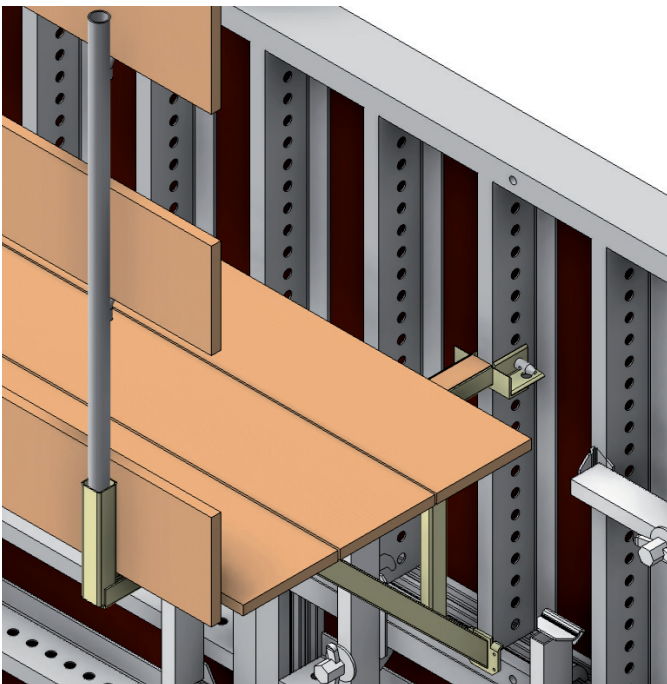
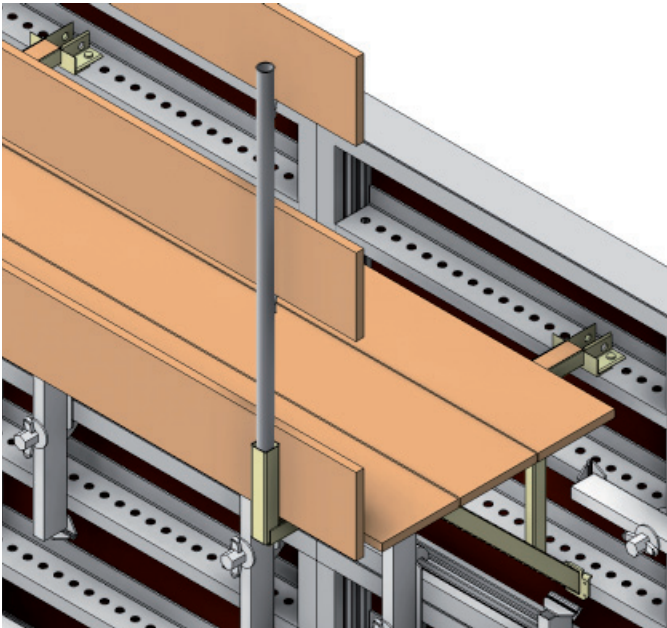

The **Vito-walkway bracket** is connected to a lying panel with the aid of a **waler bolt D 20** to the vertically arranged ribs.

Formwork Struting using Align Strut

For formwork heights of up to approx. $H = 3.90$ m the V-Strut head may be applied as depicted below. This connector is attached to one intermediate rib of the Vito panel only. Normally it should be positioned as close to the edge profile as possible (vertical panel).

V-Strut head

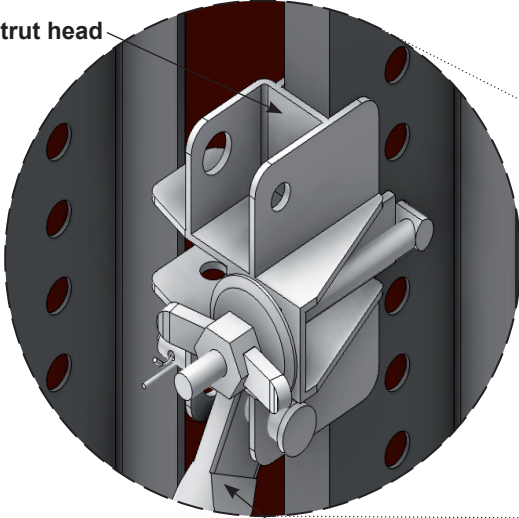

Vito-Aligning strut

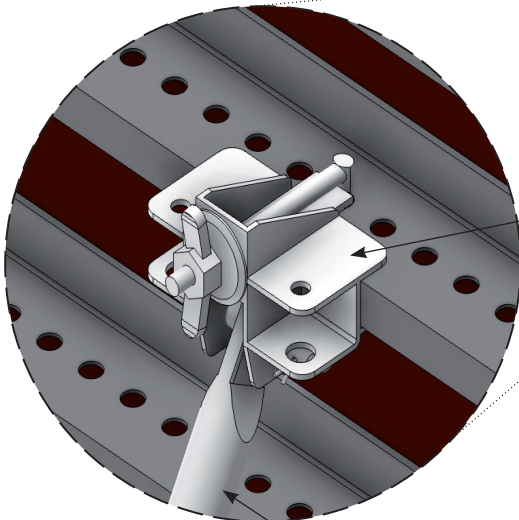

V-Strut head

Vito-Aligning strut

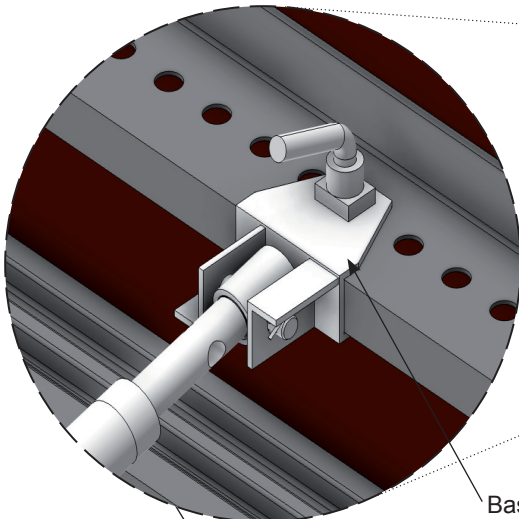

Vito-Aligning strut

Base connector align prop

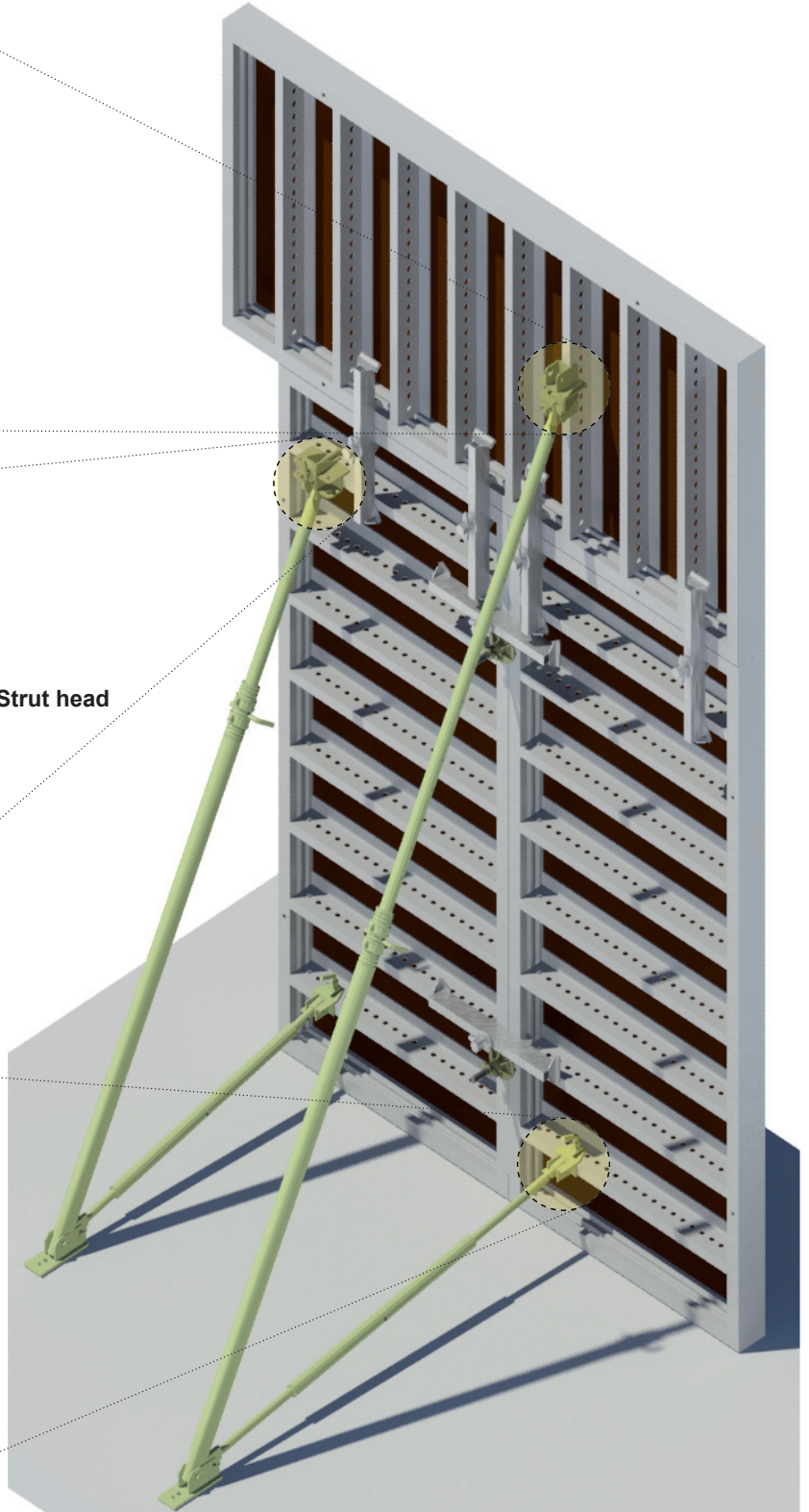

Formwork Strutting using Steel Prop

The V-Strut connector, the Strut adapter and the Strut base joint together with standard Europlus steel props can be used for additional bracing height-extended Vito formwork at shuttering heights of $H > 4.20$ m. The drill-holes provided in the connecting plates of the Strut adapter and Strut base joint allow all FFI steel props to be connected to them (always use 4 bolts M 12 x 30 with nuts for each joint).

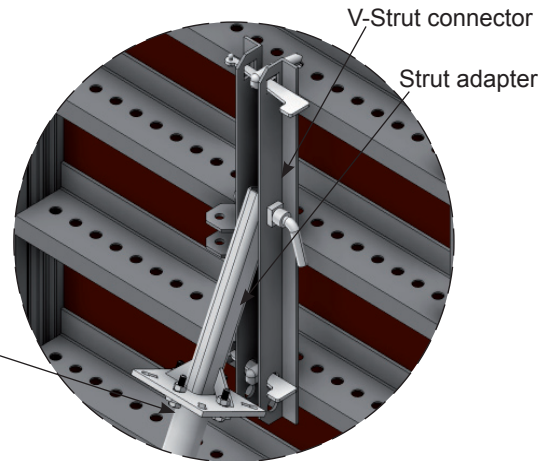
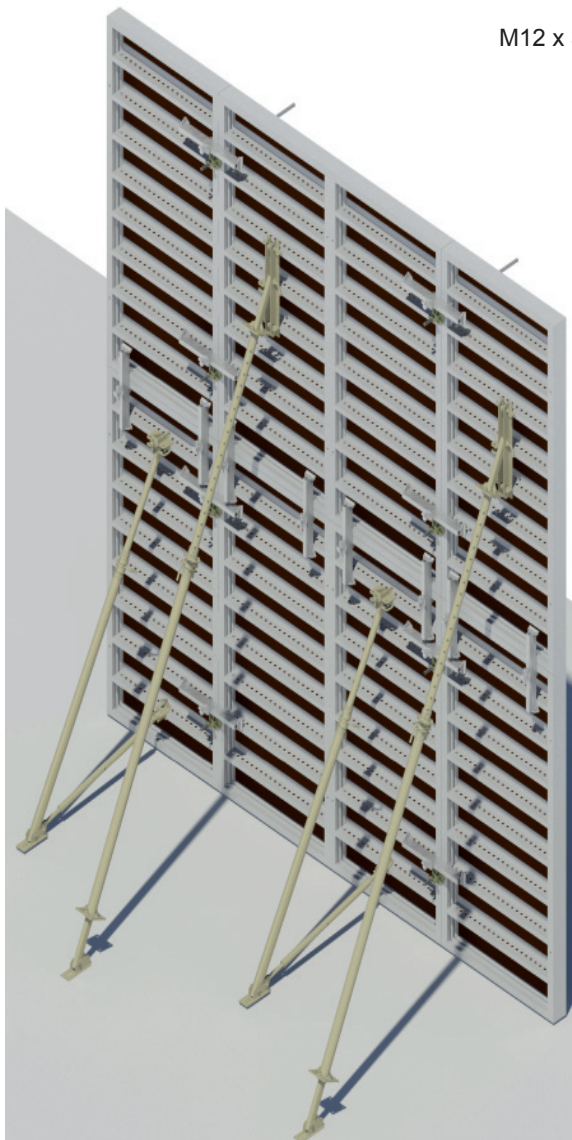

Panel Connection detail

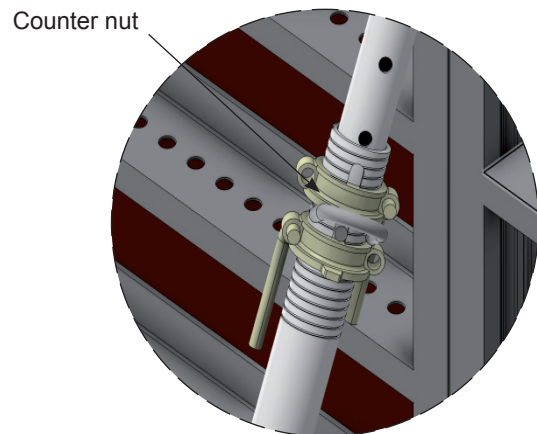

Locking with counter nut

A counter nut A/DB, AS/DB or EC/DB (depending on the chosen type of tubular steel prop) makes the steel prop tensile and pressure resistant.

Counter nut A/DB 260/300
for Europlus 260, 300 DB/DIN.
Counter nut AS/DB 350/410
for Europlus 350 DB/DIN.
Counter nut EC 400/DC 550
for Europlus 400 EC, 550 DC.

Art. no.: 107107

Art. no.: 110186

Art. no.: 110374

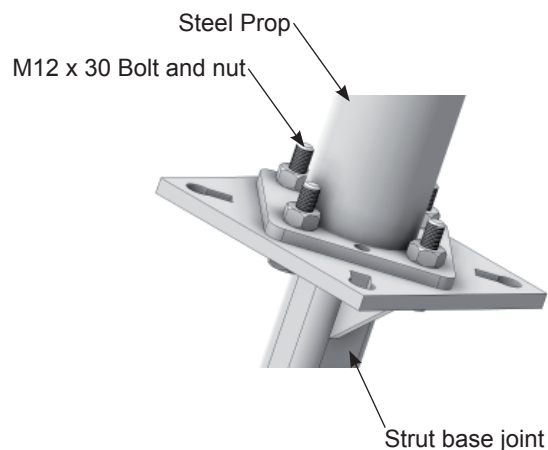

The proper type and size of steel prop has to be selected accordingly to the loading, formwork height and the extension length of the prop.

There are steel props in the product line of FFI for all ranges between 1.50 m and 5.50 m (see also relevant Load Tables).

Important!

The **permissible tension load** of the steel prop is at least **15 kN**.

Vito Shaft Formwork

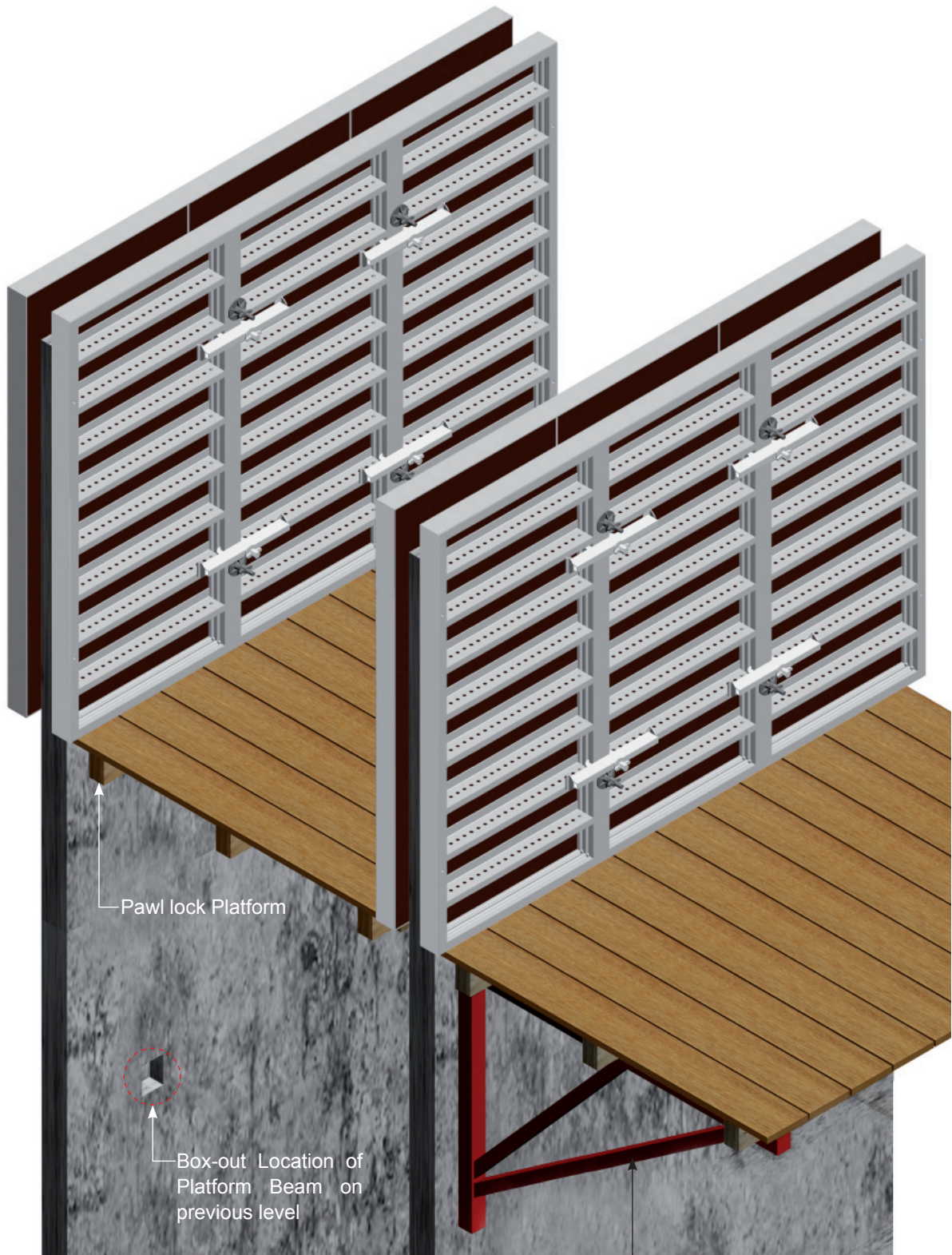

Vito Shaft Formwork Image

CB240
(For outer formwork
Refer CB240 Catalogue)

Vito shaft formwork combined with additional FFI components such as the CB 240 for the outer formwork as well as a pawl locked platform for the inner formwork.

Note:

For the folding scaffold from FFI, individual instructions for erection and use are available.

Vito Shaft Formwork

Platform beam 125-150

Platform beam 150-200

Platform beam 200-250

Platform beam 250-300

Platform beam 300-350

Platform beam 350-400

The pawl-locked platform consists of platform beams onto which an on-site squared-timber and plank cover is laid. The platform beam is always project dimensioned.

Articulated bearing claws are mounted at the ends of the double U-beam and automatically engage into the previously concreted box-outs. These can be re-used with the aid of a hang-on lag platform after shifting the pawl-locked platform.

Statical assumptions:

1. Max. spacing of platform beams: 2.50 m. Max. height of the Vito formwork: 5.40 m.
2. Load-bearing capacity of the lag platform chain must be at least 10 kN, e.g. tension chain
3. Max. live load: either pawl-locked or lag platform
 $P = 1.50 \text{ kN/m}^2$.
 Alternative single load: $F = 1.0 \text{ kN}$ at an unfavourable position.
4. The articulated claws of the platform beams require a minimum strength of concrete of 1.50 kN/cm^2 (= B15).

Dead weights:

| | |
|----------------------|----------------------------------|
| Vito formwork | : approx. 60 kg/m ² , |
| Pawl-locked platform | : approx. 70 kg/m ² , |

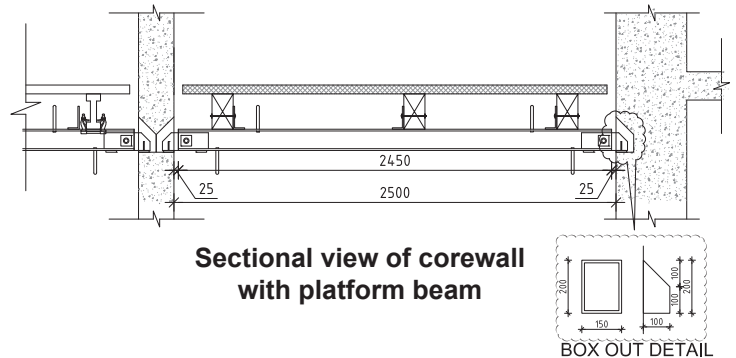
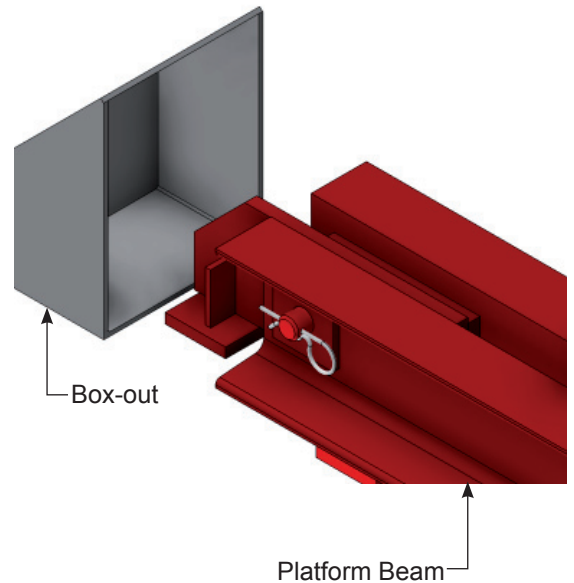
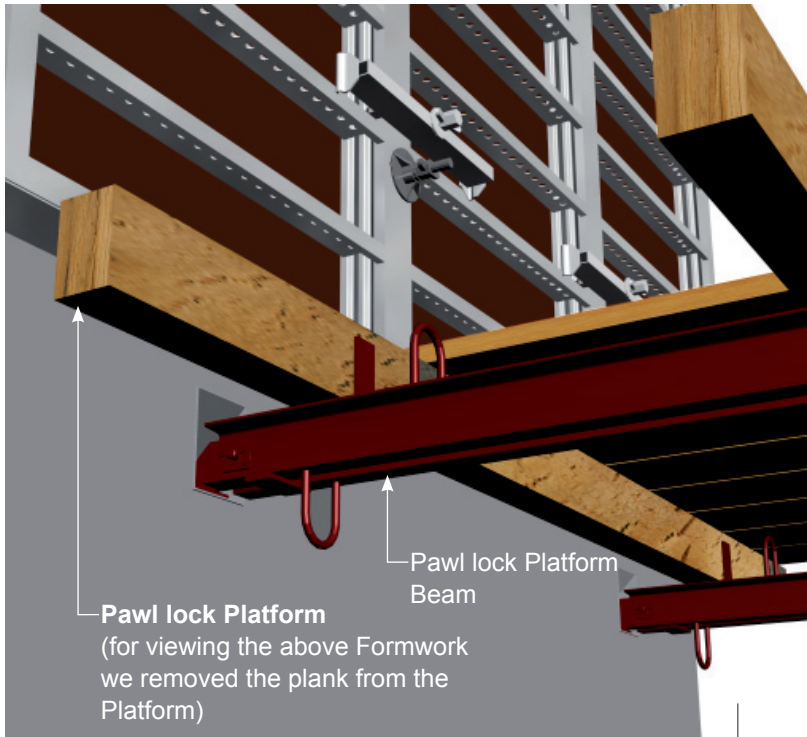

Here, the pawl of the platform beam rests in the opening of the cast-in box-out. The box-out can be removed and re-used after lifting the platform.

The correct cut-to-size length of the platform beam is calculated by the clear width of the room minus 50 mm (2 x 25 mm).

Engineering, Design & Drawing

All the Shop drawing, Technical data & the Statical calculation will be Submitted by FFI in accordance with the structural drawing project requirement

The site erection should be done as per FFI's shop drawing and shall be supervised and inspected by FFI's formwork specialist
The spacing and positioning of the Formwork material are arranged based on the statical requirements and as shown in the FFI's execution drawing & Calculation

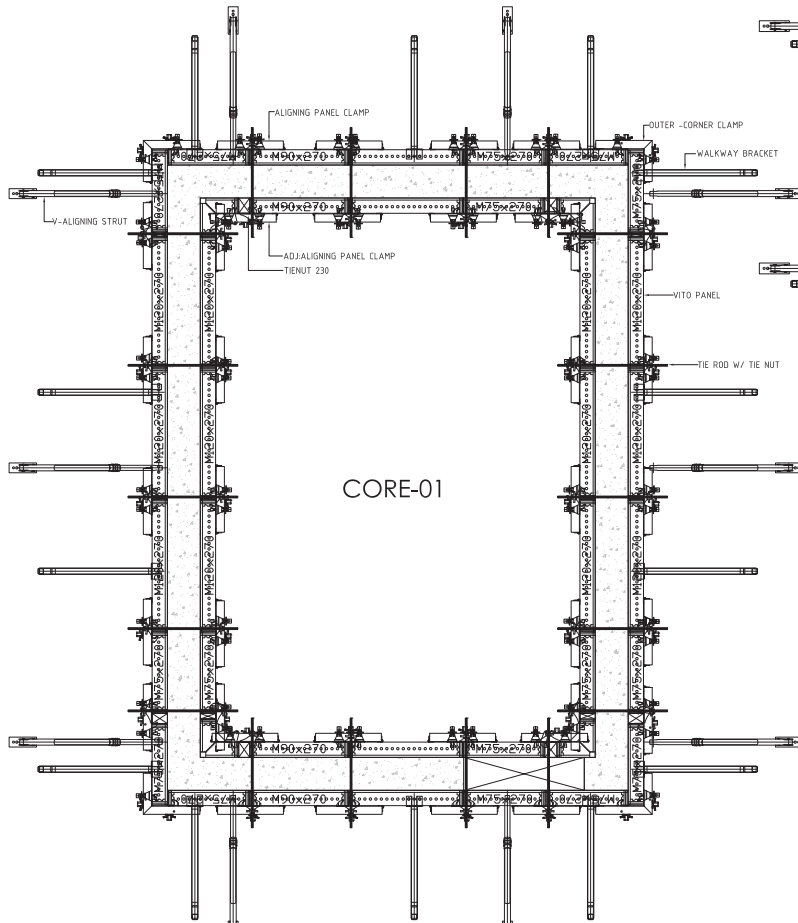

Formwork Layout of Corewall Using Vito Panel

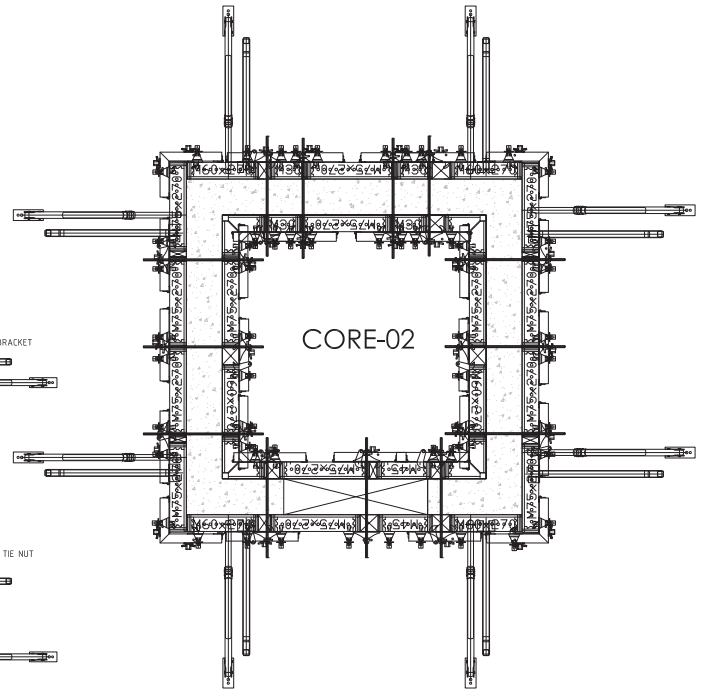

Formwork Layout of Corewall Using Vito Panel

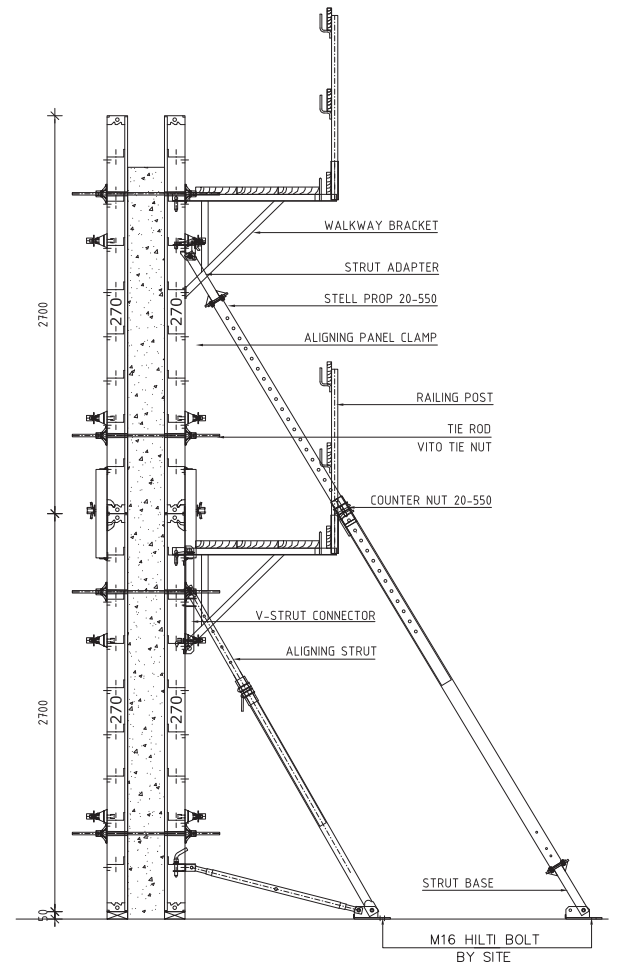

Typical Section

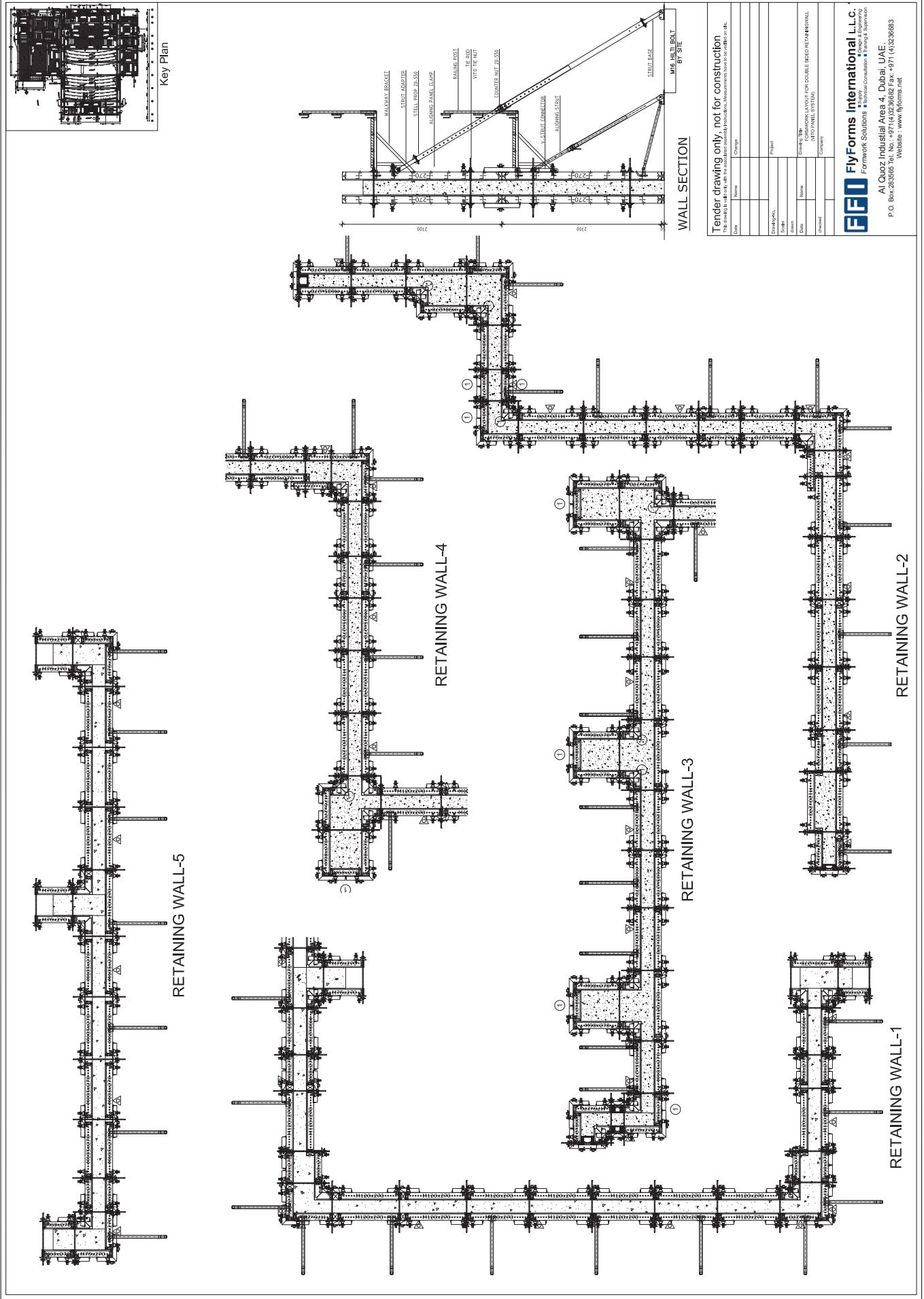

Tender drawing only, not for construction
 Use this drawing in accordance with the specifications, assembly instructions, measurements and drawings to be supplied by the manufacturer.

| | |
|-----------|--------------------------------------------------------------------|
| Date: | Change: |
| Drawn by: | Project: |
| Scale: | Site: |
| Drawn: | Formwork Type: |
| Checked: | Formwork Layout For Double Rebar Retaining Wall (VTO PANEL SYSTEM) |
| | Company: |

FFI FlyForms International LLC
 Formwork Solutions • Technical consultation • Training & Supervision
 At Quoz Industrial Area 4, Dubai, UAE.
 P.O. Box: 283656 Tel.: +971 (4) 3236862 Fax: +971 (4) 3236863
 Website: www.flyforms.net



FFI FlyForms International L.L.C. (Dubai)

Al Quoz – Industrial Area 4
P.O.Box 283565, Dubai, U.A.E
Tel. No. : +971 (4) 32 36 682
Fax. No. : +971 (4) 32 36 683
E-mail : Info@flyforms.net
Web : www.flyforms.net

FFI FlyForms International L.L.C. (Qatar)

Aziziya Commercial Complex
Aziziya Commercial Street - 424
P.O. Box : 16502 Doha, Qatar
Tel. No. : +974 - 4465 9766
Fax. No. : +974 - 4456 7250
E-mail : Info@flyforms.net
Web : www.flyforms.net

All Rights Reserved For Flyforms International L.L.C.

All material and information provided on this document unless specifically noted otherwise, is copyrighted material owned by flyforms international L.L.C.

Any individual or company making unauthorized usage and copies of FFI material will be subjected to the penalties as per the U.A.E law and regulation