



**FlyForms International L.L.C.**

Formwork Solutions ■ Supply ■ Design & Engineering  
■ Technical Consultation ■ Training & Supervision



# Climbing Bracket CBM 240

Assembly and Application Guide

# Product Information & Features

## Contents

Product Information & Features .....	2
Product Overview .....	3
Components .....	4-6
Erection Procedure.....	8-9
Working Platform System.....	10
Alignment.....	11
Anchoring Details .....	12
Operation.....	13
Anchoring Details .....	14
Engineering, Design & Drawing.....	15

## Product Features

Flyforms Climbing Bracket CBM240 is an economic, durable and easy to use system that provides a safe and versatile solution to climbing vertical shuttering support and protected working area that is ideal for high structures with successive lifts.

Due to its high level of flexibility and adaptability, the CBM 240 system can be used in almost any situation where a vertical formwork or edge protection system is required. It can be used in conjunction with a self-climbing system or anchored directly to the existing structure. It is compatible with a wide variety of different formwork shuttering systems and can also be used as a standalone external climbing edge protection system.

The system has a high load capacity of 50kn per bracket and up to 6m shuttering capability, providing a safe working area during all stages of operation. The main platform has a large 2.4m wide working area and allows for shutter retraction of up to 75cm from the concrete surface.

The system is optimal for multiple swift work-cycles, with its low maintenance and reduced manpower required for shuttering and de-shuttering, the simplified erection procedure greatly reduces the possibility of human error and subsequently increases structural accuracy and overall safety.

The CBM240 can be easily erected, adjusted and struck without the use of crane and can be shifted vertically individually or as a joint system comprised of multiple units. With its capability of variable angle, the degree of incline can easily be adjusted and/or fixed to whatever the structural requirements are.

The Climbing Bracket CBM240 is designed and manufactured in accordance with BS EN 12182 : 2008, code of practice for Falsework

## Important Remarks

The succeeding instructions for assembly and application have to be carefully read as it contains detailed information regarding the proper application and handling of the FFI climbing Bracket CBM240 System. All instructions concerning technical operation and function have to be observed carefully. Please note that exceptional use of the FFI Aluminium Table Form Slab System requires a separate design calculation.

In order to ensure a technical and safe use of our product, all relevant national safety rules and regulations and safety instructions of national institutes and/or local authorities have to be observed. In general, only undamaged material and components which are in proper condition must be used.

It is important that damaged components are sorted out and removed from the construction site. In case of repairs, only original spare parts of FFI must be used.

The use of FFI formwork systems combined with other supplier's materials may involve certain dangers and require an additional inspection and quality check by our formwork specialist.

Due to technical development of our system, we would like to emphasize that FFI reserves the right to revise, change, or modify any of the product's components at any time without prior notice.



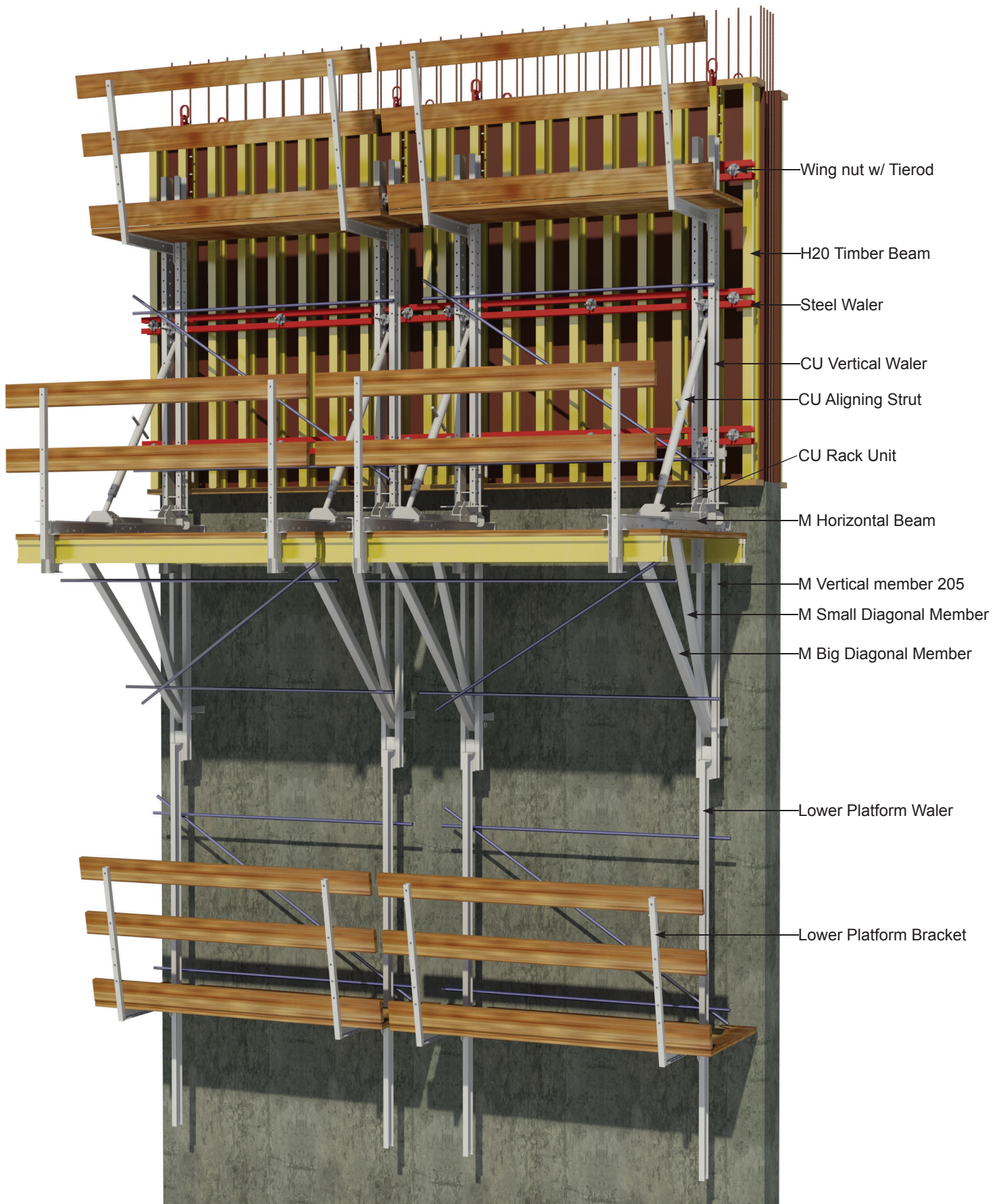

# Product Overview

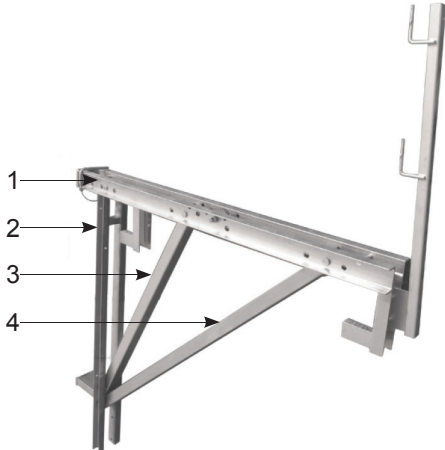
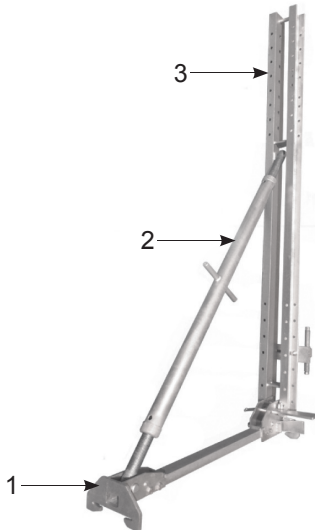
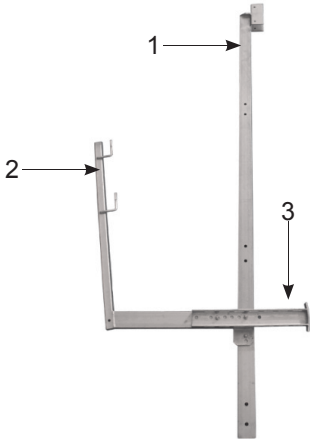
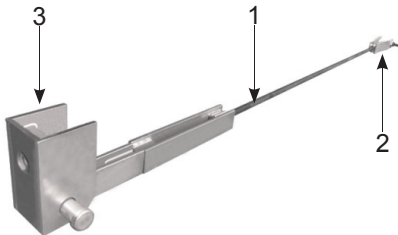

# Components

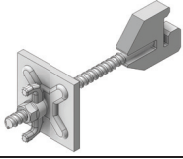
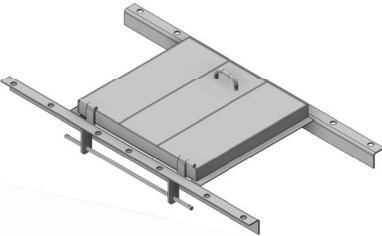
	Art. No	Weight Kg/pc.	
<b>Climbing Bracket CBM240</b> <b>1.) M Horizontal Beam</b> (L=251cm, H=155cm) <b>2.) M Vertical member 205</b> (H=213cm) <b>3.) M Small Diagonal Member</b> <b>4.) M Big Diagonal Member</b>	803CBM24	172.10	
	803HB240	88.09	
	803VM205	39.95	
	803BD253	24.75	
	803SD183	16.31	
<b>CU Carriage Unit</b> <b>1.) CU Rack Unit</b> (L=128cm, H=22cm) <b>2.) CU Aligning Strut</b> (L=166 to 229 cm) <b>3.) CU Vertical Waler</b> (H=260cm)	803CU260	135.75	
	803RU128	32.35	
	803AS226	26.55	
	803VW260	76.85	
<b>Suspended Platform Bracket</b> <b>1.) Lower Platform Waler</b> (H=368 cm) <b>2.) M Platform Bracket</b> (L=133cm,H=152 cm) <b>3.) Platform Waler Spacer</b> (L=71cm)	803PW340	50.80	
	803PB114	19.05	
	803PS700	7.28	
<b>Wind Tension Bar</b> <b>1.) Wind Tension Bar</b> <b>2.) Wind Anchorage Upper Element</b> <b>3.) Wind Anchorage Lower Element</b>	803TB570	3.95	
	803UWA40	3.50	
	803LWA30	7.15	



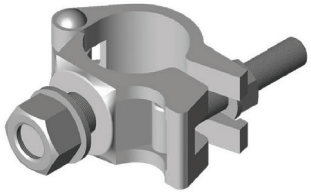
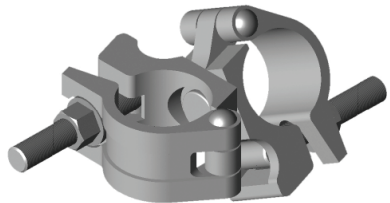



# Components

	Art. No	Weight Kg/pc.	
<p><b>Waler Holder Hook</b></p> <p>Clamps Horizontal walers on shutter to CU Vertical Waler.</p>	101FH014	2.50	
<p><b>Passage 60x60</b> (L=134cm, W=72cm)</p> <p>Provides safe access to platforms and closes penetrations.</p>	803PP660	40.00	
<p><b>Starting Element</b> (L=143 cm, W=19 cm)</p> <p>Enables carriage unit to be launched directly from slab level.</p>	803SE143	23.15	
<p><b>M Swivel Plate</b> (L=29 cm, H=20 cm)</p> <p>Performs variable angle adjustment of M Platform Bracket when used at any degree of inclination.</p>	208MSP30	4.50	
<p><b>Handrail Clamps S</b> (H=123 cm to 171 cm)</p> <p>Clamp-on edge protection, typically used for stop-ends and areas not accessible for the M Handrail Post.</p>	201HS116	11.40	
<p><b>Screw On Coupler</b></p> <p>Fixes bracing tube directly to CU Vertical Waler &amp; Vertical Profile 205.</p>	301SOC90	0.76	
	301SOC40	0.67	
<p><b>Swivel Coupler 48</b></p> <p>Fixes 48mm tube to tube at any angle.</p>	301DSC48	1.20	

# Components

	Art. No	Weight Kg/pc.	
<p><b>Anchor Plate 140</b> Cast into the concrete and provides the anchoring point from which the Climbing bracket CBM240 is suspended.</p>	315AP40D	1.02	
<p><b>Climbing cone 30/M24</b> Serves as the main suspension point for the Climbing Bracket and is also used to maintain position of the Anchor Plate whilst casting in place.</p>	803CC324	0.60	
<p><b>PVC Sleeve</b> Enables the Climbing Cone to be easily removed after casting in concrete.</p>	803PCS30	0.016	
<p><b>Cone Bolt 80</b> Used to Secure the Climbing Bracket to the Climbing cone 30/M24. It is also used to maintain position of the Anchor Plate whilst casting in place in conjunction with the Climbing Cone 30/M24.</p>	803BH248	0.375	
<p><b>Naillable Fixing Disc</b> Used to fix the Climbing Cone directly to the forms' surface in instances where a penetration cannot be made through which to fix the Cone Bolt.</p>	803NFD60	0.108	
<p><b>Mounting Ring M24</b> Safety mechanism which retains climbing bracket in place at anchoring point.</p>	803MR375	0.308	
<p><b>UNI Cone Square Spanner</b> Used to remove the Climbing Cone 30/M24.</p>	803UCS18	0.85	
<p><b>Plate Washer Nut 15</b></p>	315PW119	1.4	
<p><b>Tie Rod 15</b> Safety Warning: Never weld or heat tie-rods (risk of fracture)!</p>	315TR100	1.4	

# Components

	Art. No	Weight Kg/pc.	
<b>M Vertical Member 160</b> (H=208cm)	803VM160	90.50	
<b>CU Vertical Waler Extension</b> (H=144cm)	803VWE14	41.50	
<b>M Preassure Strut</b> (H = 166cm to 226cm)	803PS225	26.00	
<b>M Big Diagonal Member</b> <b>M Small Diagonal Member</b>	803BD253 803SD183	24.75 16.31	
<b>Reversable Ratchet 50</b>	306RRS50	1.41	
<b>Hex Socket M36</b> <b>Hex Socket M24</b>	306HSS36 306HSS24	0.486 0.217	

# Erection Procedure

The standard Climbing Bracket CBM240 is comprised of five main components.

Variation of these components makes it possible to customize the setup to whatever the site requirement. In standard configuration, the Climbing Bracket CBM240 is set at a 90 degree angle to the walls surface for climbing vertically. For a particular angle of inclination, the Big and Small Diagonal members' length can be substituted to suit the site requirement. Should the requirement be for a varied or changing degree of inclination, these Diagonal members can be substituted for the M Pressure strut which can be adjusted to suit the degree of incline as required.

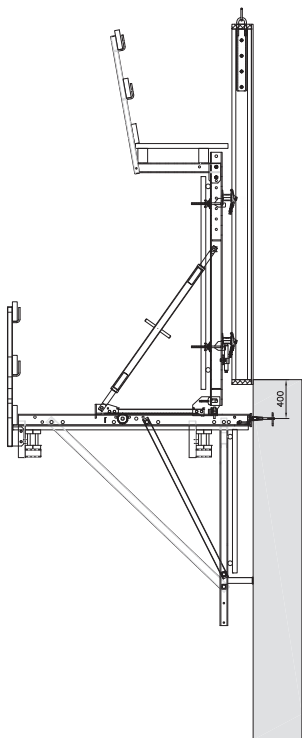
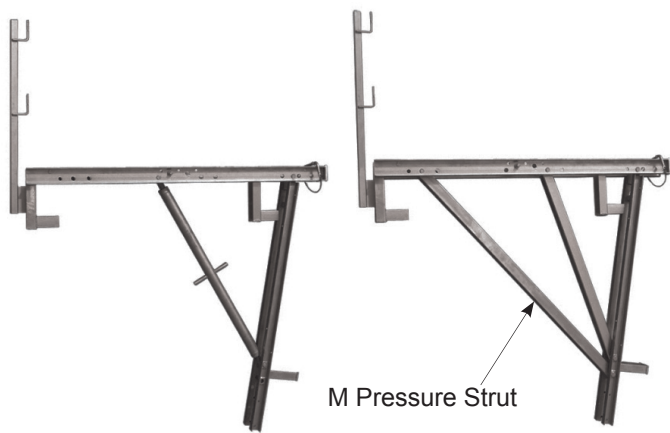
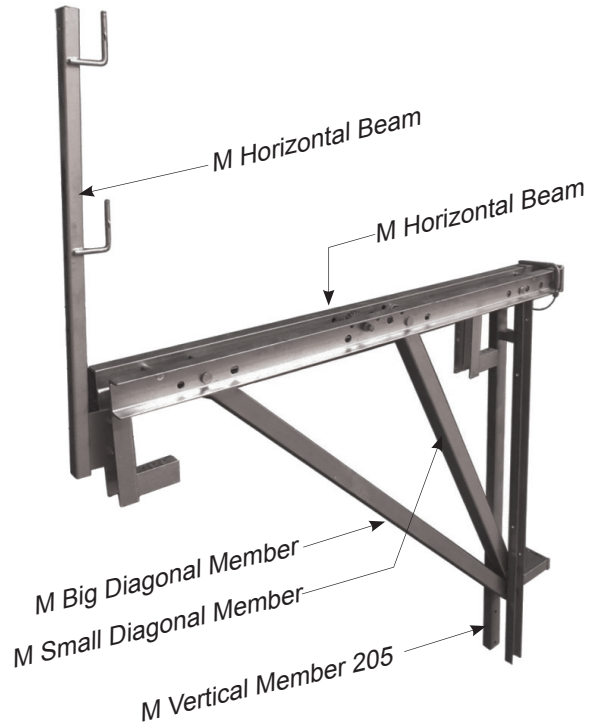

Vertical Wall

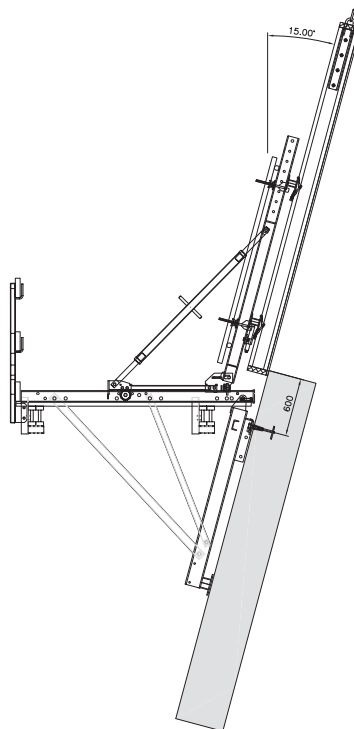

Fixed Incline

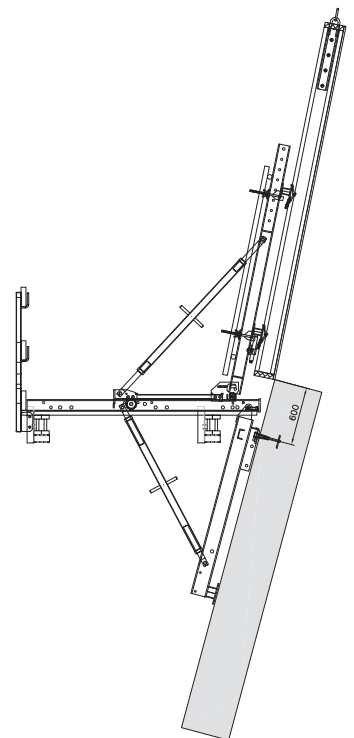

Variable Incline



# Erection Procedure

The Carriage Unit, used in conjunction with the Climbing Bracket CBM240 forms the main element used to support the formwork and to aid shuttering and de-shuttering procedures without the use of the crane. It is composed of 3 main components that form the complete shifting unit.

The CU Gear travels back and forth along the Climbing Bracket CBM240 M Horizontal Beam and shifts the CU Vertical Waler to and from the concrete surface by turning of the CU Gear. This procedure allows for swift alignment of the bottom of the form to the concrete surface. The CU Alignment Strut then performs any required adjustment for plumbing the panel vertically against the casting surface. This procedure is reversed when striking the form and allows workers to do so unaided.

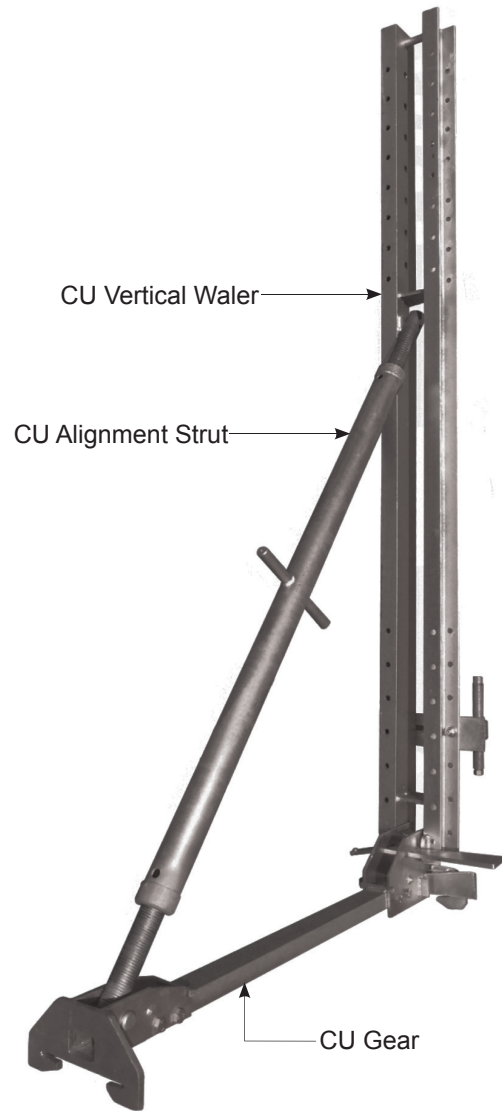

The walers of the formwork shutter panel rest on Height Adjusting Unit on the CU Vertical Waler which easily perform any required adjustment of the panel parallel to the casting surface.

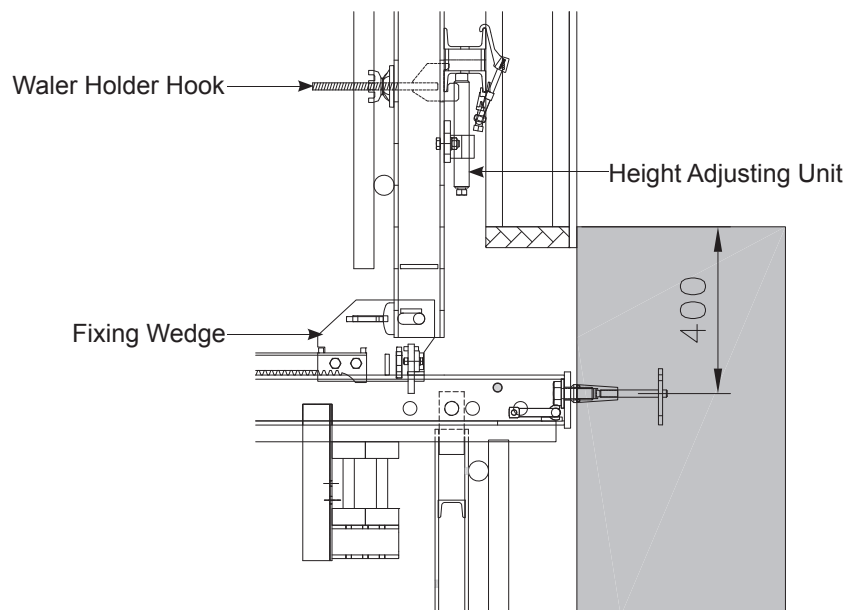

# Working Platform System

The CBM240 Climbing System is not only used as shuttering support, but also provides a complete and comfortable safety system during all stages of use.

The M Platform Bracket is fixed as a pouring platform at the form top of the shutter on the CU Vertical Waler providing safe access for pouring work.

The M Handrail Post fixes to the Climbing Bracket CBM240 to form the edge protection barrier.

The main platform of the Climbing Bracket CBM240 features a wide 2.4 meters of working area and allows for 750mm of shutter retraction, enabling ease of access for steel work, fixing the climbing cones and other pre/post-cast processes.

The Lower Platform Waler is used to suspend the M Platform Bracket below the CBM240 allowing for fixing/removal of the Wind Tension Belt and Climbing Cone.

M Swivel Plate allows for levelling of the M Platform Bracket when using on an inclined surface.

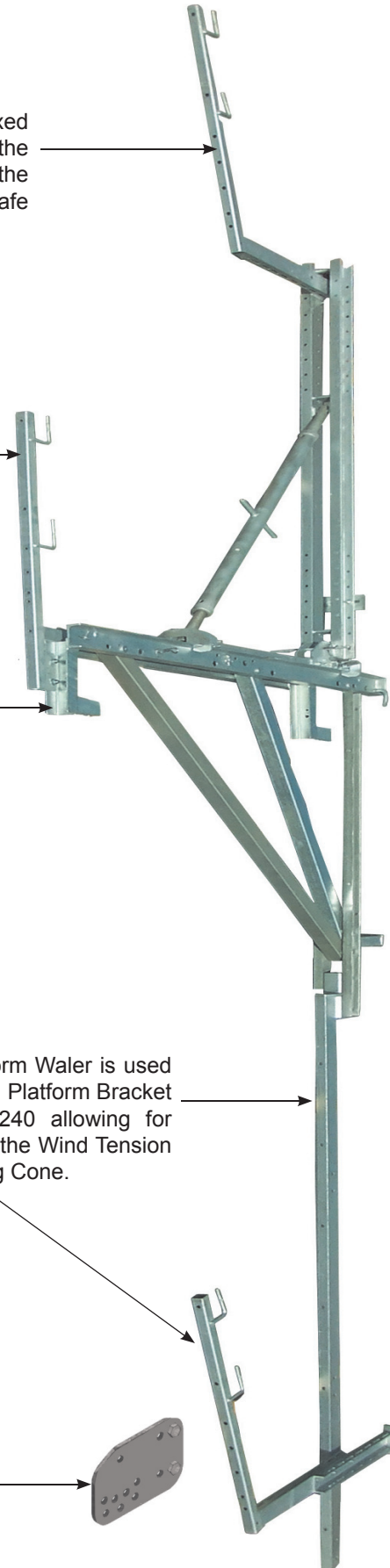

# Alignment

The Climbing Bracket CBM240 system has a built in adjustment system that allows for swift and precise adjustability at the swing of a hammer.

Simply by releasing the Fixing Wedge and Waler Holder Hooks, the form can be easily manipulated and aligned as required. By adjusting the Height Adjusting Unit up or down at either end of the panel, the form can be tilted left or right or moved up and down respectively.

As the weight of the shutter rests on these adjusters by the steel waler, friction between the two is greatly reduced enabling side to side movement with little effort.

After final adjustments have been made, tighten the Waler Holder Hook and engage the Fixing Wedge to establish a firm connection to the support system and lock the shutter in place ready for concrete placing.

Any final plumbing of the panel can be easily done via the CU Alignment Strut.

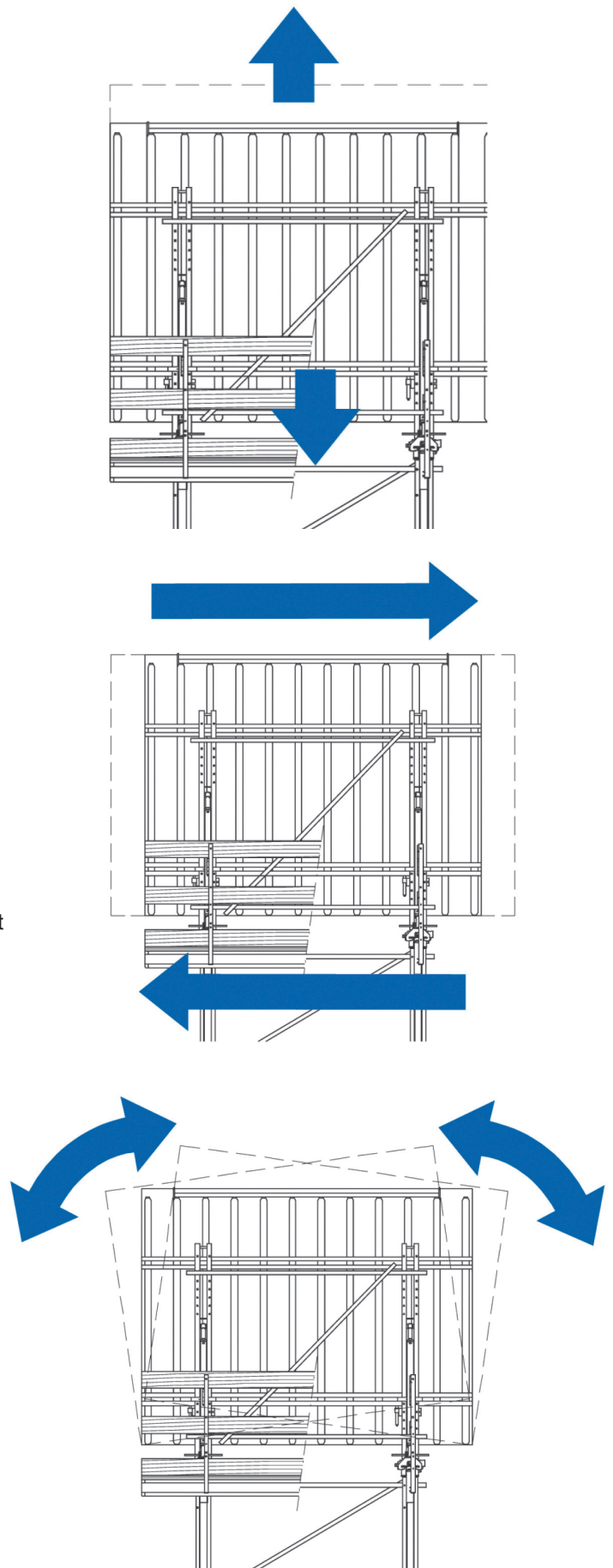
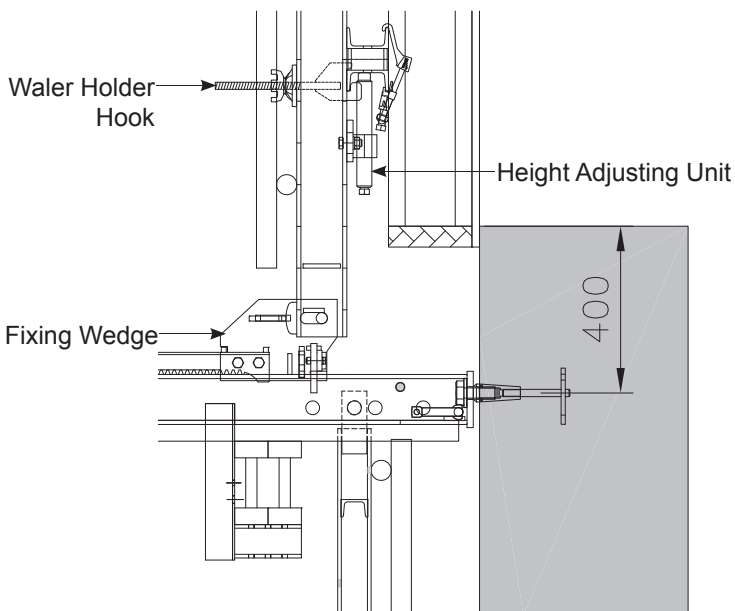

# Anchoring Details

The same components are used for both suspending the Climbing Bracket and positioning the anchors while casting.

## Cone Bolt 80

Used to Secure the Climbing Bracket to the Universal Climbing cone. It is also used to maintain position of the Anchor Plate whilst casting in place in conjunction with Climbing Cone 30/M24.

## Mounting Ring

Safety mechanism which retains climbing bracket in place at anchoring point.

## Climbing Cone 30/M24

Serves as the main suspension point for the Climbing Bracket and is also used to maintain position of the Anchor Plate, whilst casting in place

## PVC Sleeve

Enables the Climbing Cone to be easily removed after casting in concrete.

## Anchor Plate

Is cast into the concrete and provides the anchoring point from which the Climbing Bracket CBM240 is suspended.

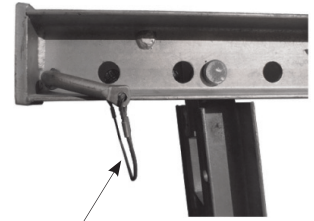

## Safety Pin

Must be inserted after suspending the Climbing Bracket to prevent it from being lifted out.



## Nailable Fixing Disk

is used to fix the Climbing Cone directly to the forms' surface in instances where a penetration cannot be made through which to fix the Cone Bolt.

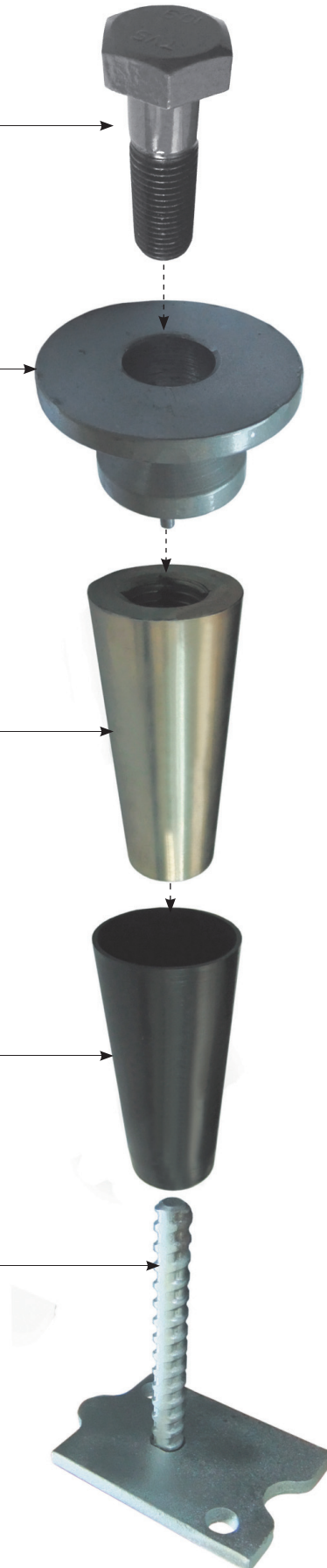

# Operation

## Launching Procedure

To cast the first wall section, the carriage unit must be launched at ground level from the Starting Element, anchored to the slab. The first set of anchor plates are cast into the wall at this level, allowing the climbing brackets to be suspended from the climbing cones at this anchor point during the 2nd stage.

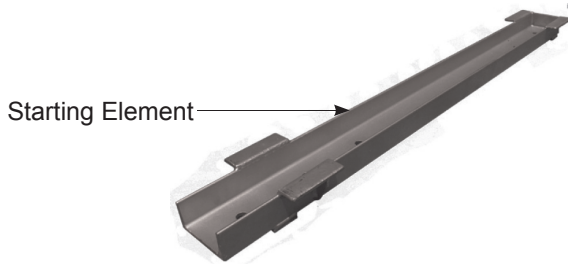
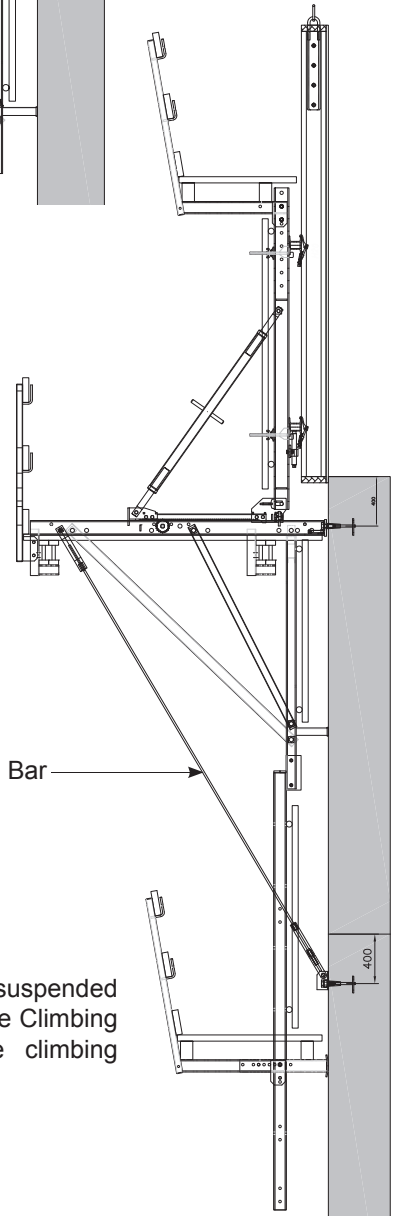
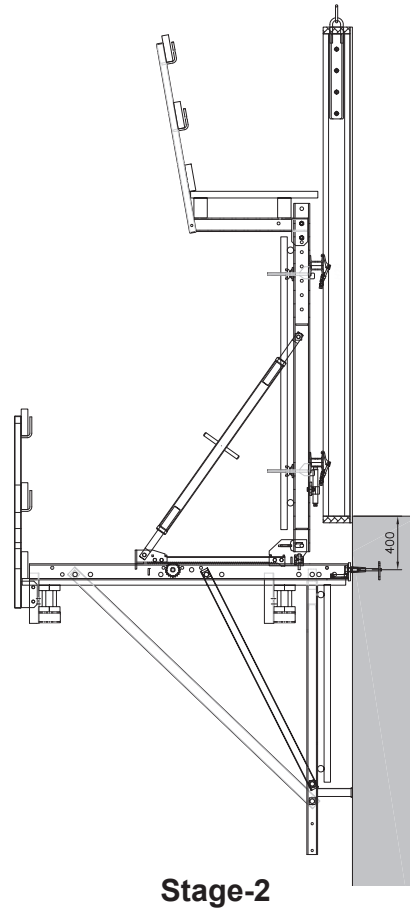
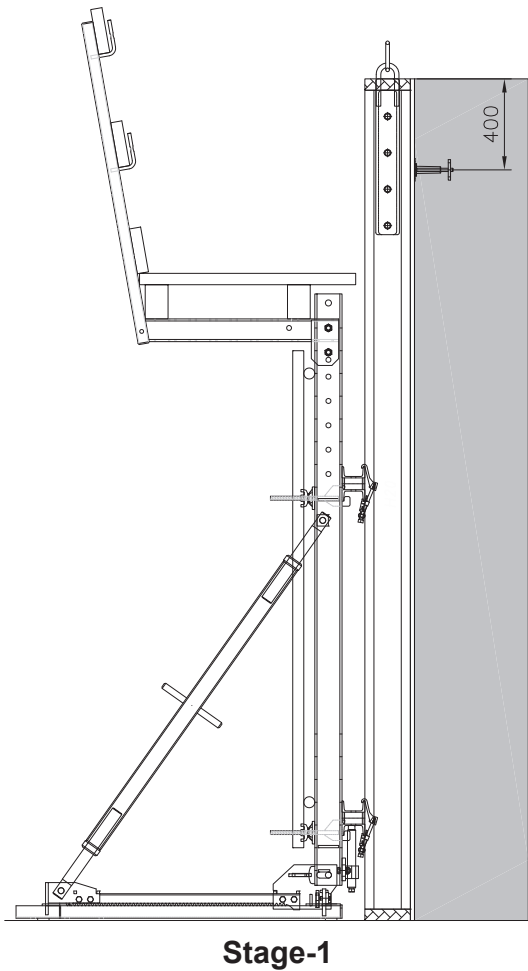

By the 3rd pouring stage the suspended platform is added below the Climbing Bracket to complete the climbing system.

# Anchoring Details

## Stage-1

Release the fixing wedge and pressing wedge and remove the Cone Bolt 80 to release the climbing cone 30/M24 from the shutter surface. The shutter can now be struck from the concrete and retracted with the carriage unit by turning the CU Gear.

Prepare the next suspension point by fixing the Cone Bolt 80 and Mounting Ring M24 to the climbing cone 30/M24 (still fixed to the cast-in Anchor Plate).

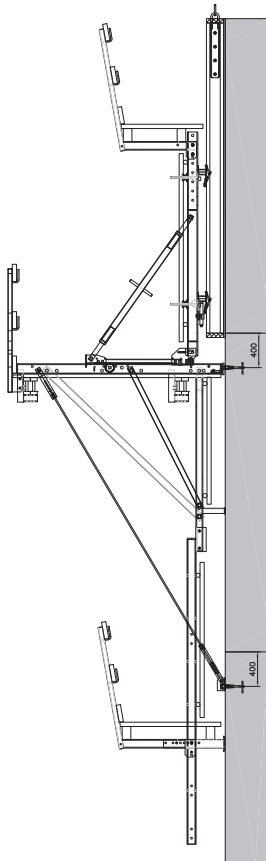

Stage-1

## Stage-2

Remove the Wind Tension Bar and retrieve any anchoring components, working from the suspended platform.

Fix the Carriage Unit as close to the centre of gravity point as possible.

Remove the safety Pins and attach the crane sling to the CU Vertical Waler

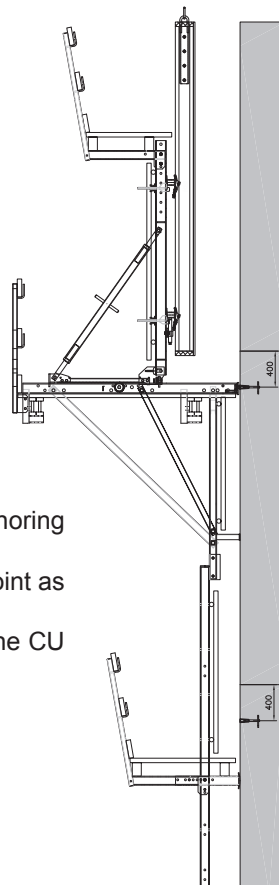

Stage-2

## Stage-3

Lift the unit with the crane to the next prepared suspension point and replace the safety pin and Wind Tension Bar.

Move the Carriage Unit into position by turning the CU Gear using a  $\frac{3}{4}$ " 2-Way Ratchet.

Secure the Carriage Unit to the Climbing Bracket by striking the Fixing Wedge. This must be also be secured before leaving unattended or lifting by crane.

Tighten the shutter against the existing wall section by striking the pressing wedge. This locks the shutter in position and ensures a tight seal at the base of the shutter.

Fit anchor components to be cast in and plumb the shutter by turning of the CU Aligning Strut. Fit form ties and pour concrete.

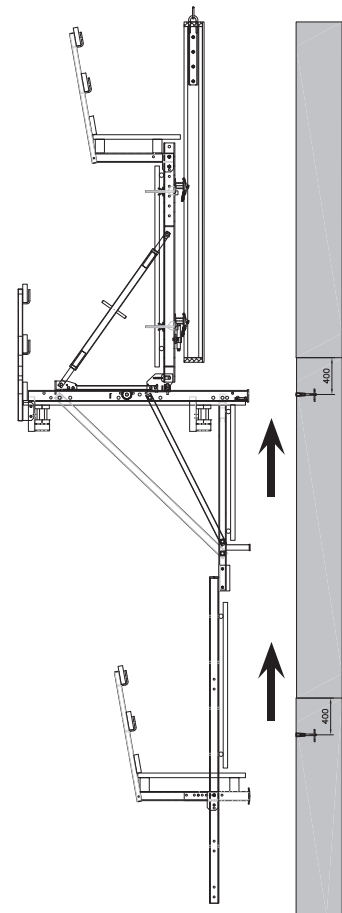

Stage-3

- A. All the Shop drawing, Technical data & the Statical calculation will be Submitted by FFI in accordance with the structural drawing project requirement
- B. The site erection should be done as per FFI's shop drawing and shall be supervised and inspected by FFI's formwork specialist
- C. The spacing and positioning of the Formwork material are arranged based on the statical requirements and as shown in the FFI's execution drawing & Calculation

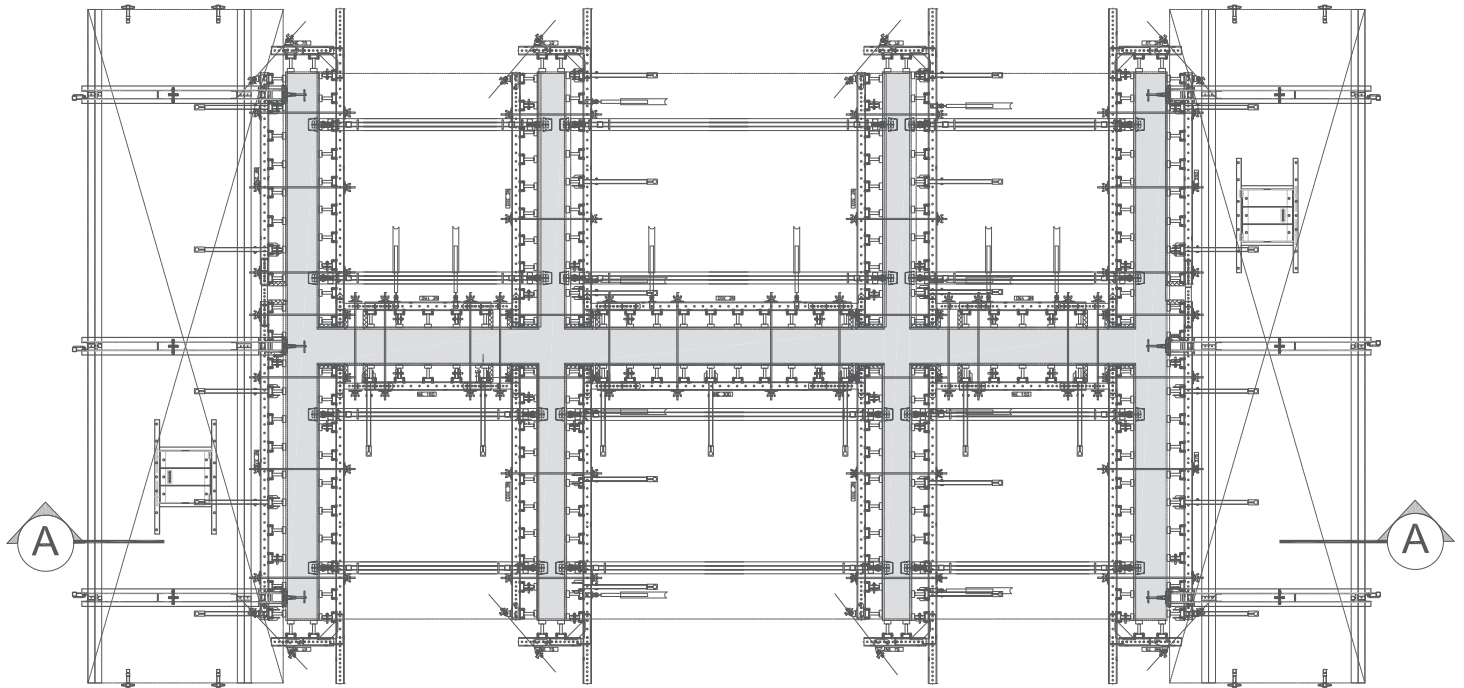

**Formwork Layout of Corewall using CBM240**

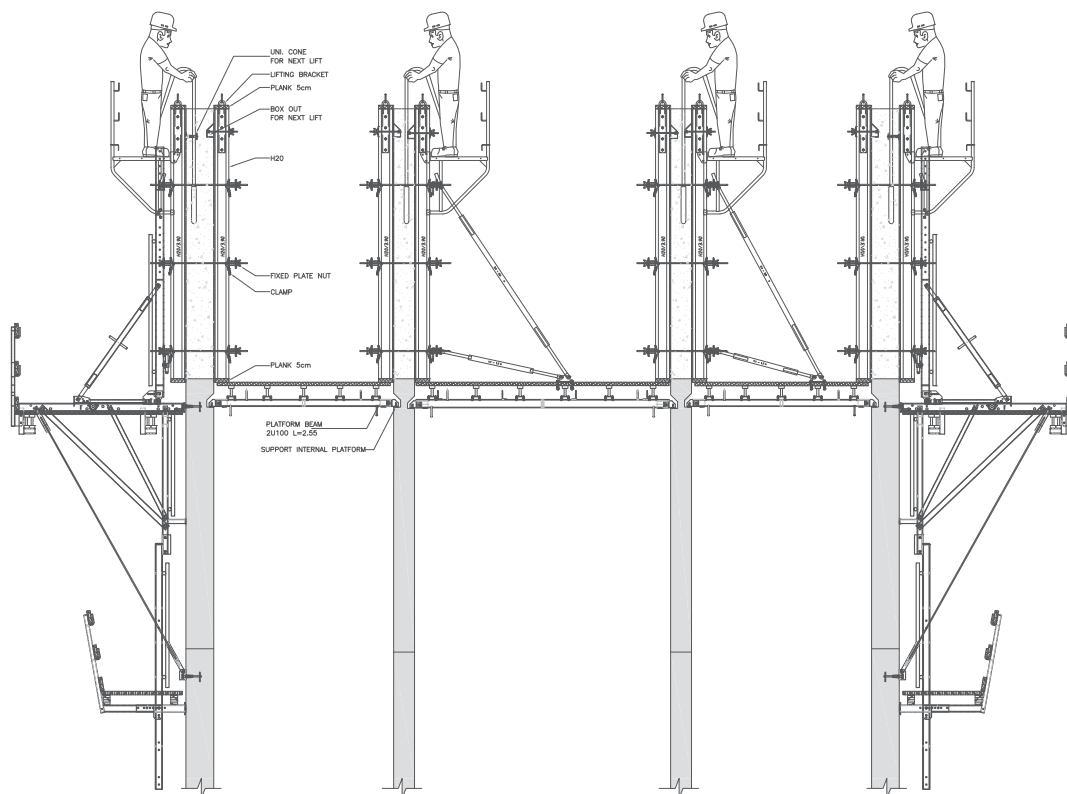

**Section A-A**



**FFI FlyForms International L.L.C. (Dubai)**

Al Quoz – Industrial Area 4  
P.O.Box 283565, Dubai, U.A.E  
Tel. No. : +971 (4) 32 36 682  
Fax. No. : +971 (4) 32 36 683  
E-mail : [Info@flyforms.net](mailto:Info@flyforms.net)  
Web : [www.flyforms.net](http://www.flyforms.net)

**FFI FlyForms International L.L.C. (Qatar)**

Aziziya Commercial Complex  
Aziziya Commercial Street - 424  
P.O. Box : 16502 Doha, Qatar  
Tel. No. : +974 - 4465 9766  
Fax. No. : +974 - 4456 7250  
E-mail : [Info@flyforms.net](mailto:Info@flyforms.net)  
Web : [www.flyforms.net](http://www.flyforms.net)

**All Rights Reserved For Flyforms International L.L.C.**

All material and information provided on this document unless specifically noted otherwise, is copyrighted material owned by flyforms international L.L.C.

Any individual or company making unauthorized usage and copies of FFI material will be subjected to the penalties as per the U.A.E law and regulation