



FlyForms International L.L.C.

Formwork Solutions ■ Supply ■ Design & Engineering
■ Technical Consultation ■ Training & Supervision



CT Shoring Tower System

Assembly and Application Guide

Product Information and Features

Contents

Product Information and Features.....	2
Product Overview.....	3
Components.....	4-5
Erection Procedure.....	6-7
Dismantling.....	8
Engineering, Design & Drawing.....	9-11

Product Features

The FFI CT Shoring Tower System benefits from the FCD coupling system, (a self-locking pivoting wedge that hooks into a stirrup) so that towers can be linked together quickly with ease and safety. As soon as a triangular frame is positioned on a stirrup, the edge pivots automatically, instantaneously securing the system:

- quicker erection in complete safety,
 - fewer erection personnel needed.
- Meaning less time and greater efficiency.

Owing to its triangular design, the CT Shoring Tower System ensures active safety throughout erection. The CT Shoring Tower System's triangular frame & ledger act as guardrails for the erectors. The steel platforms of the Crab range can also be fitted to the triangles to provide a working platform in complete safety.

In most cases only 5 components are needed to erect CT Shoring towers. Erection is extremely simple and is carried out very quickly by assembling:

- The basic standard, the triangular frame, the CT head jack, the adjustable base jack, the ledger.

On complicated sites, the CT Shoring Tower can be fitted as an option with telescopic components that fit to the top or bottom of the towers and can be used to increase the nominal height of the towers by about 1.20 m.

The towers can be extended laterally using FCD linking components into any configuration necessary for the site. CT Shoring towers can be shifted in 2 ways:

- With a crane. In this case they should be bolted using the usual erection practices,
- Using the shifting frame.

The CT Shoring Tower System is designed and manufactured in accordance with BS EN 12182 : 2008, code of practice for Falsework

Important Remarks

The succeeding instructions for assembly and application have to be carefully read as it contains detailed information regarding the proper application and handling of the CT Shoring Tower System. All instructions concerning technical operation and function have to be observed carefully. Please note that exceptional use of CT Shoring Tower System requires a separate design calculation.

In order to ensure a technical and safe use of our product, all relevant national safety rules and regulations and safety instructions of national institutes and/or local authorities must be observed. In general, only undamaged material and components which are in proper condition must be used.

It is important that damaged components are sorted out and removed from the construction site. In case of repairs, only original spare parts of FFI must be used. The use of FFI formwork systems combined with other supplier's materials may involve certain dangers and require an additional inspection and quality check by our formwork specialist.

Due to technical development of our system, we would like to emphasize that FFI reserves the right to revise, change, or modify any of the product's components at any time without prior notice.

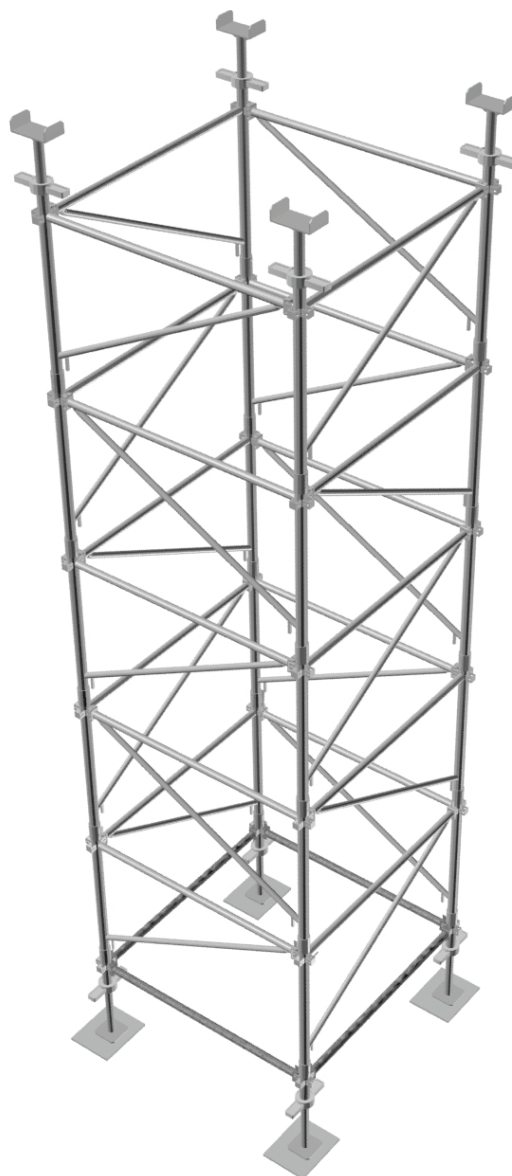

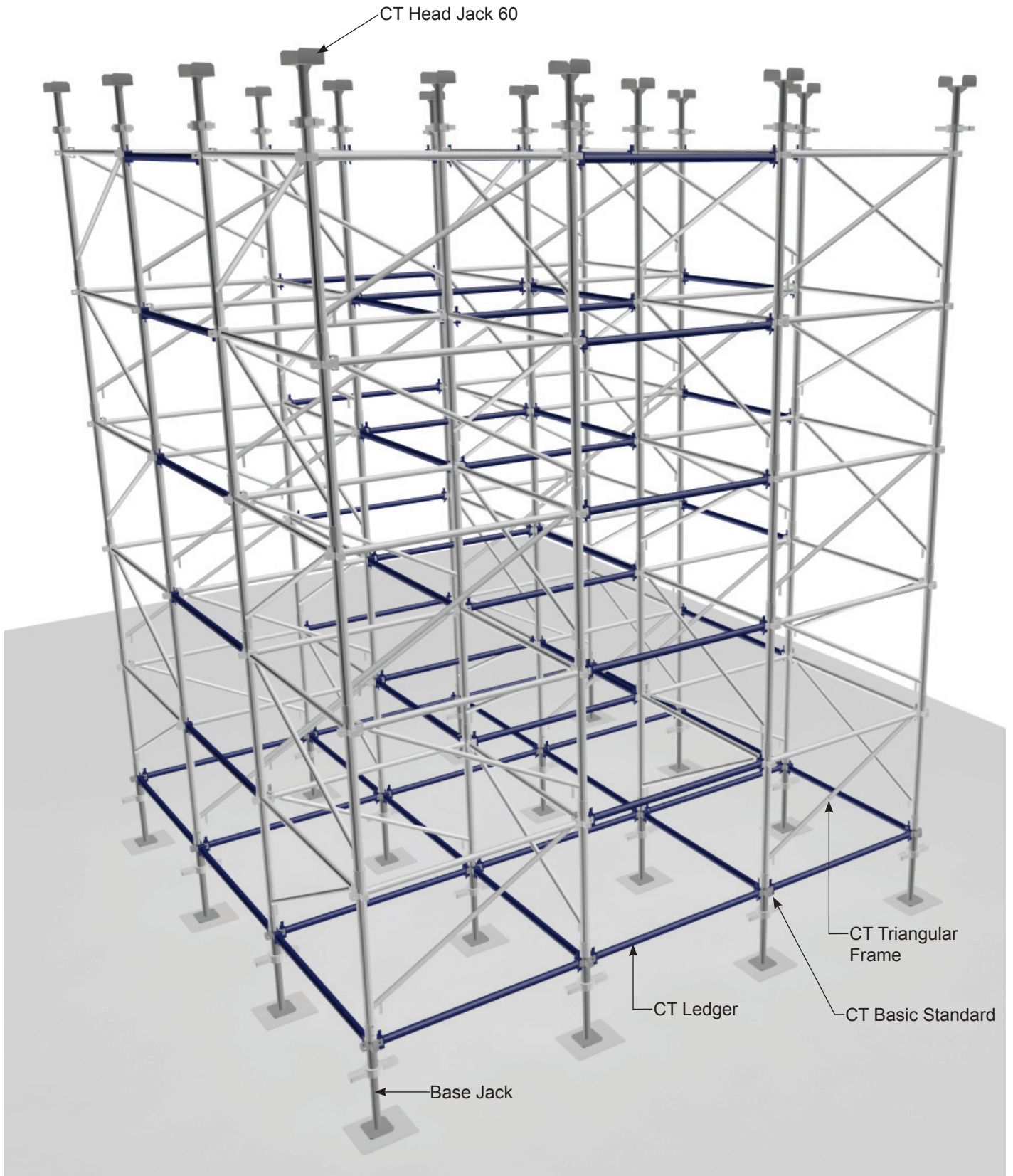

Product Overview

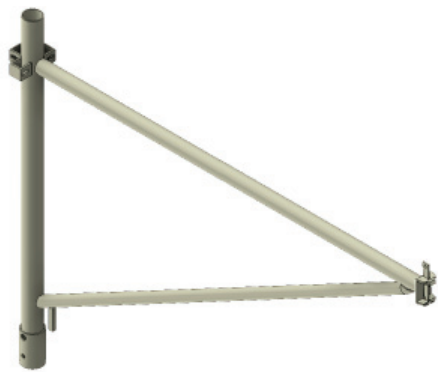

Components

	Art. No	Weight Kg/pc.	
CT Triangular Frame 1.00 x 1.50m	704TF150	11.87	
CT Triangular Frame 1.00 x 0.70m	704TF050	9.058	
CT Base Jack 60	704BJ060	4.88	
CT Head Jack 60	704HJ060	6.19	

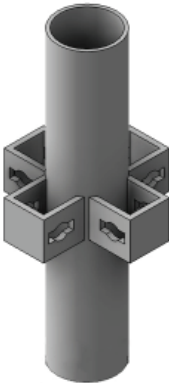
Components

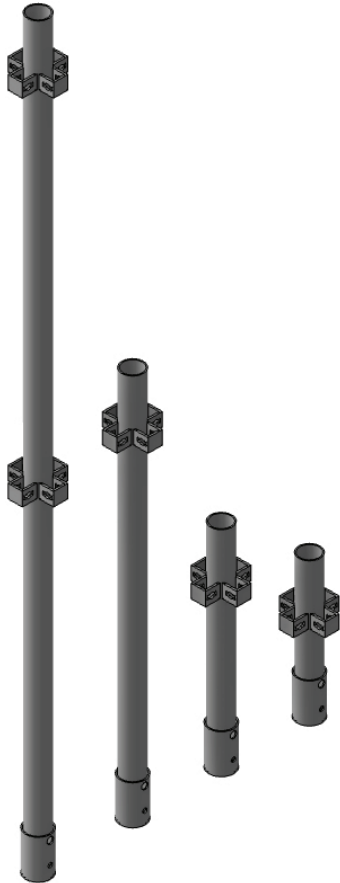
	Art. No	Weight Kg/pc.	
CT Basic Standard 0.30m	704BS030	1.8	
CT Ledger 0.50m	704LD050	1.71	
CT Ledger 0.70m	704LD070	2.20	
CT Ledger 1.00m	704LD100	3.07	
CT Ledger 1.20m	704LD120	3.57	
CT Ledger 1.50m	704LD150	4.59	
CT Standard 0.30m	704ST030	2.42	
CT Standard 0.50m	704ST050	3.26	
CT Standard 1.00m	704ST100	5.40	
CT Standard 2.00m	704ST200	10.26	

Erection Procedure

Step-1

Place CT base jack on load distribution sole plates at distances determined by the CT Ledger. The Basic standards are fitted on the Base jack. Lay the first planned diagonals, bushes downwards.

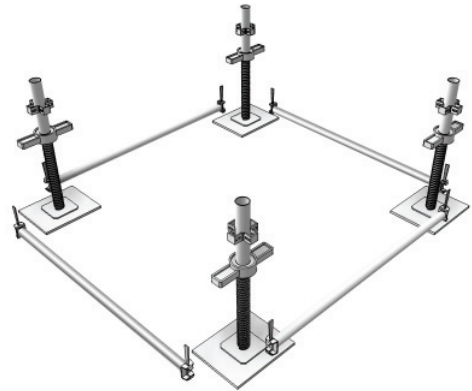

Step-2

Wedge the first CT Ledgers. Fit and lock the first stage of CT Triangular Frames Level and plumb the structure.

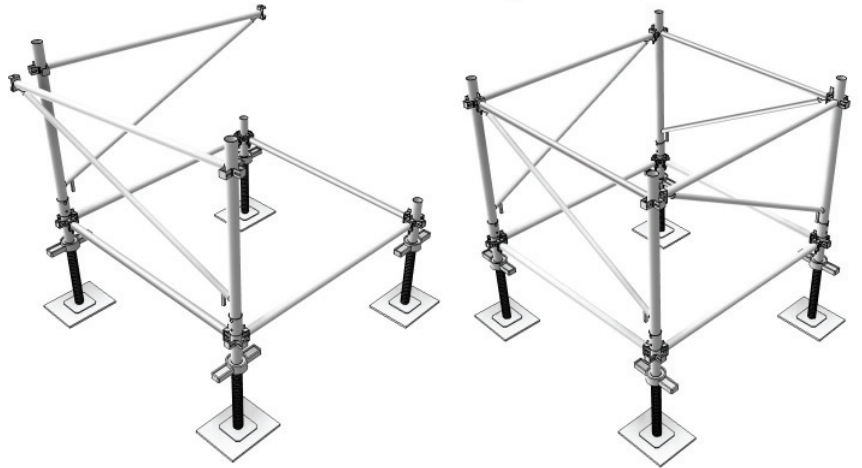

Step-3

Place additional base jacks and basic standards, connections to the existing frame assembly using CT Ledgers. Install the second level of triangular Frames, again from the ground upwards. Reverse the direction of the Frames. Triangular Frames must be pinned together.

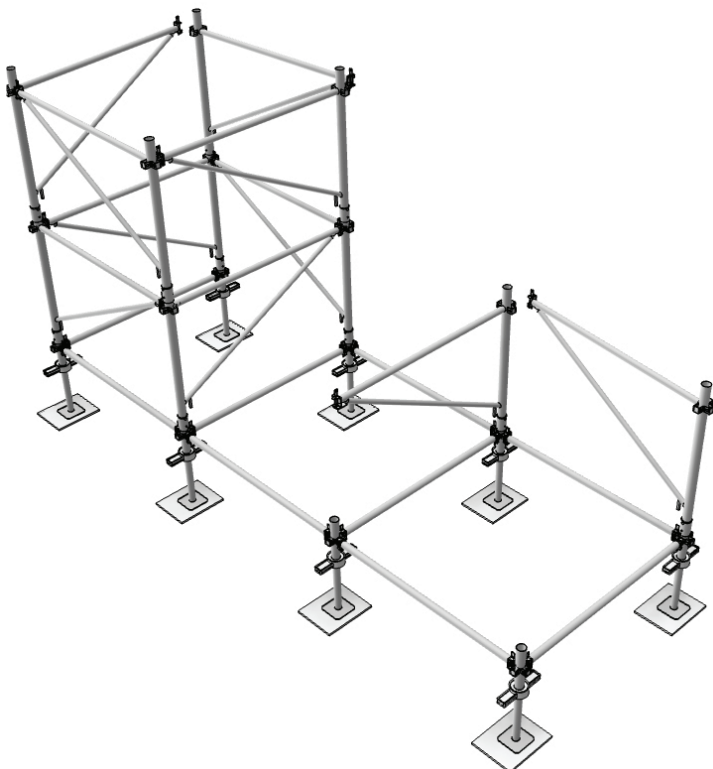

Step-4

Install temporary working platforms. Carefully check that the structure is plumb using the sighting device present on all the triangle sleeves. The upper and lower tubes should be in contact at each leg. Erection must be carried out from inside the towers.

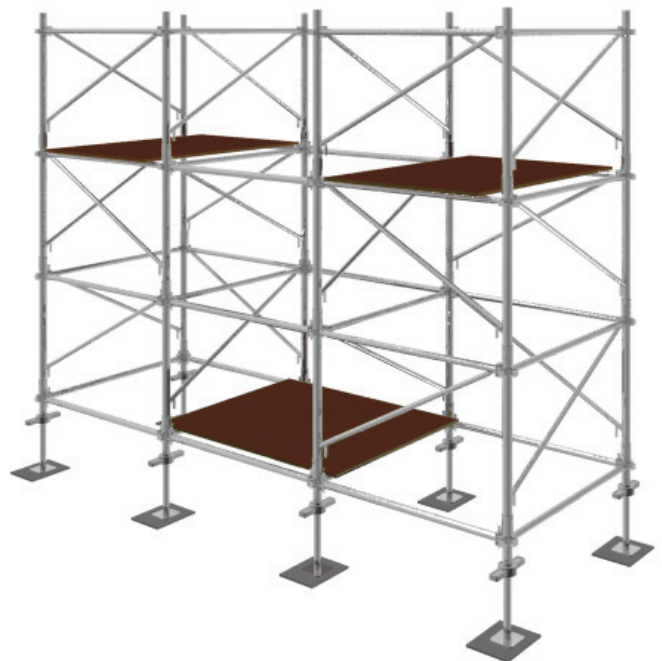

Erection Procedure

Step-5

Move the temporary platform from below level to one level above. Fit and lock the triangle frames at the present level. The direction of the triangle frames should be reversed

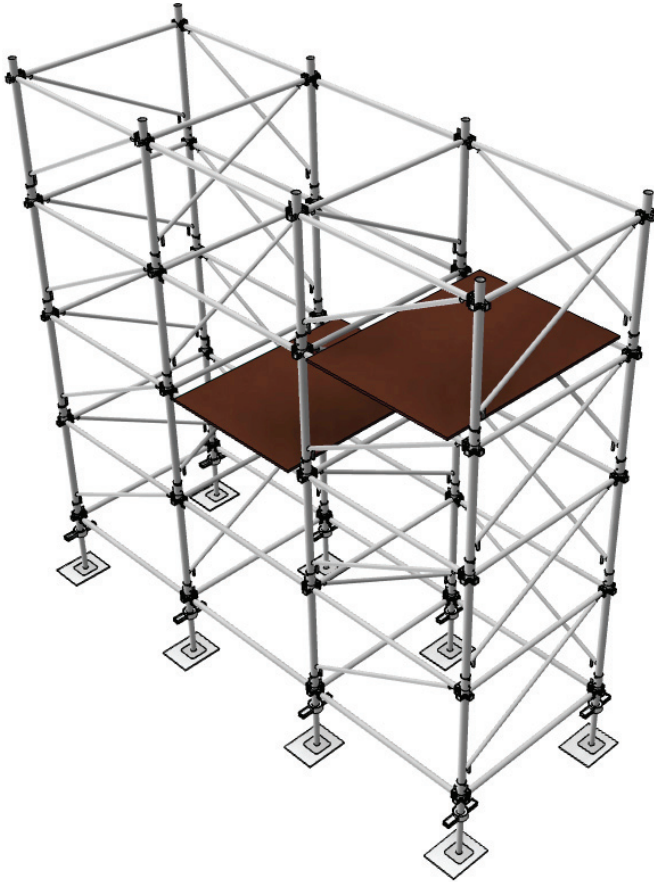

Step-6

Connect up the adjustable cell with the CT Ledger; diagonal braces adjusted to the cell size must be installed. Position the head Jack on the Last CT Triangular frame

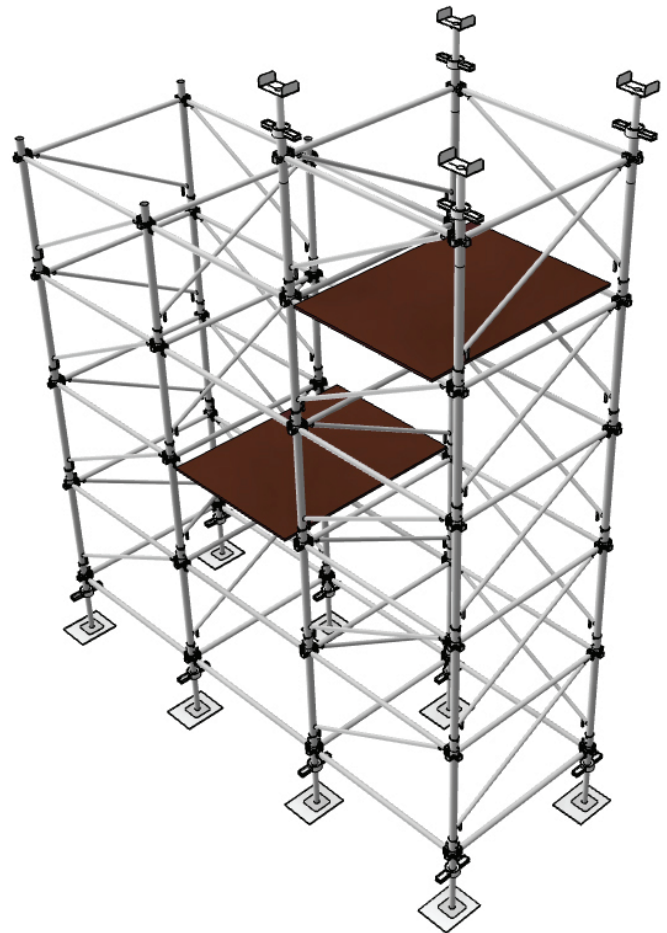

Step-7

Finish off the service platform for installing the joists, girders, or shuttering panels. This platform must remain in place to give access for checking the underside of the slab, for leveling, removing formwork and dismantling.

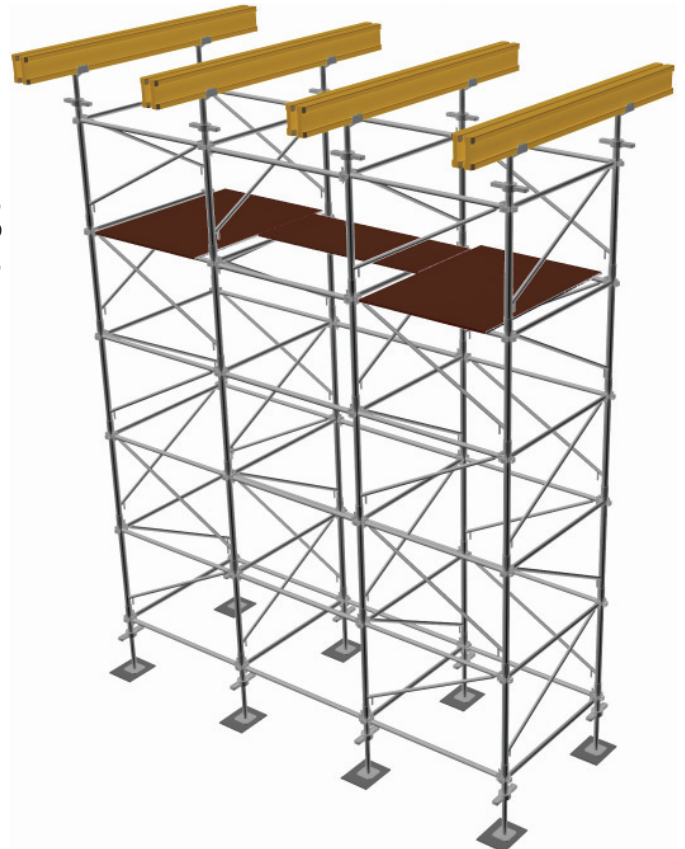

Dismantling

Step-1

Release the head jack and wind down to create room to remove the formwork.

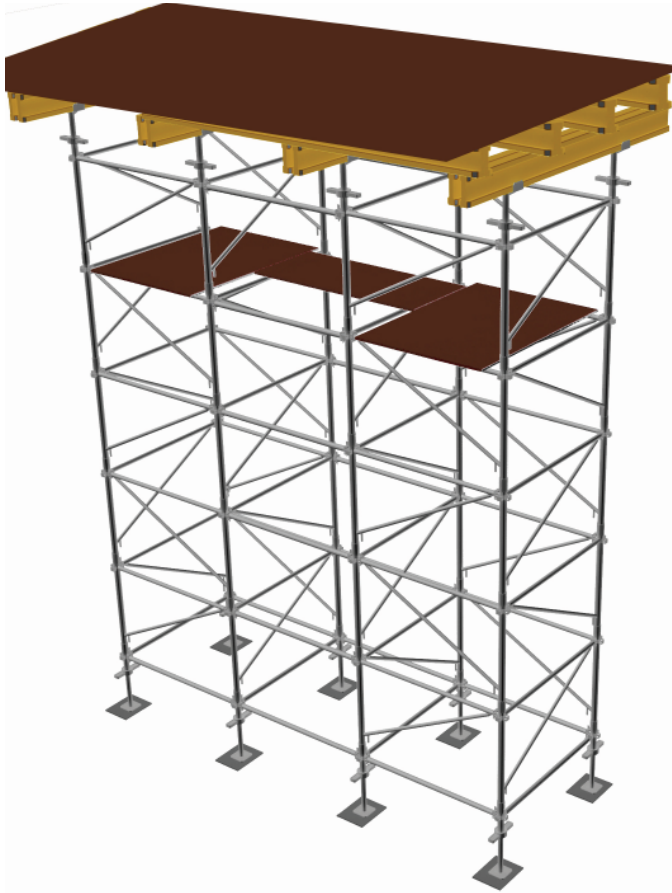

Step-2

Gently pry the formwork from the concrete surface. Remove the plywood, H20 beam and Head jacks.

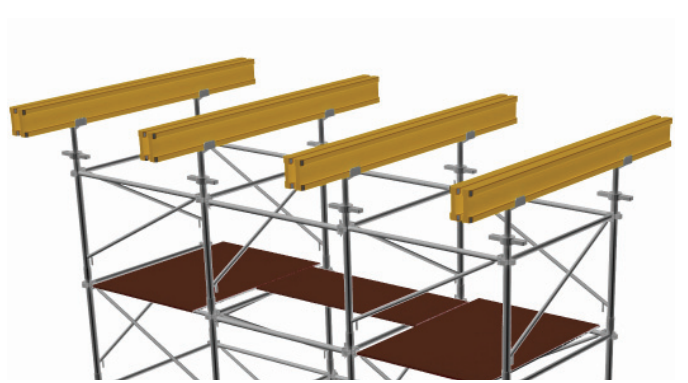

Step-3

Lower the top level access platform to the bay below to enable safe removal of the top level of triangular frames.

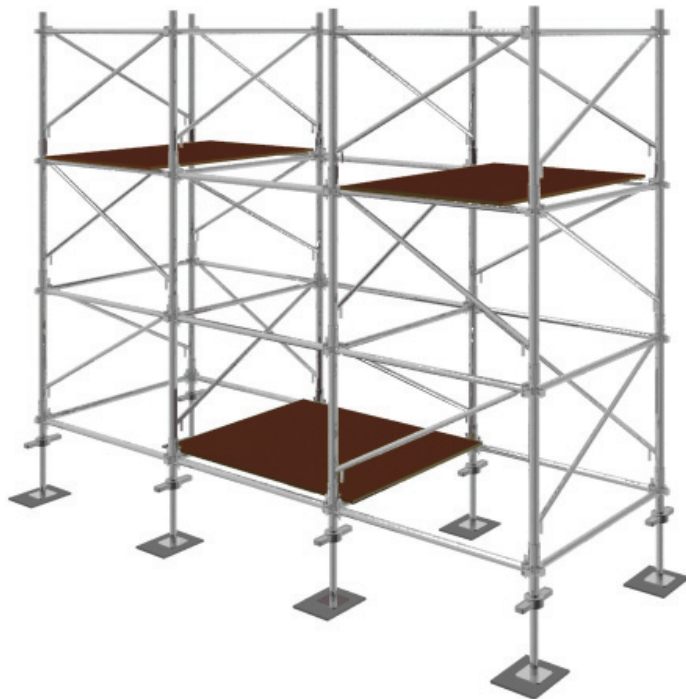

Step-4

These can now be safely removed by working from behind the rails. Repeat this process to safely dismantle the frames to ground level

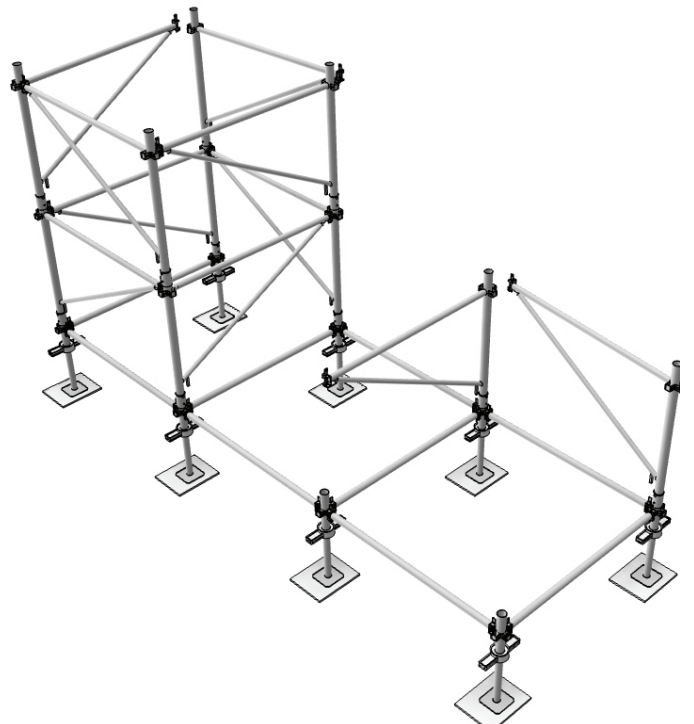

Engineering, Design & Drawing

- A. All the Shop drawing, Technical data & the Statical calculation will be Submitted by FFI in accordance with the structural drawing project requirement
- B. The site erection should be done as per FFI's shop drawing and shall be supervised and inspected by FFI's formwork specialist
- C. The spacing and positioning of the Formwork material are arranged based on the statical requirements and as shown in the FFI's execution drawing & Calculation

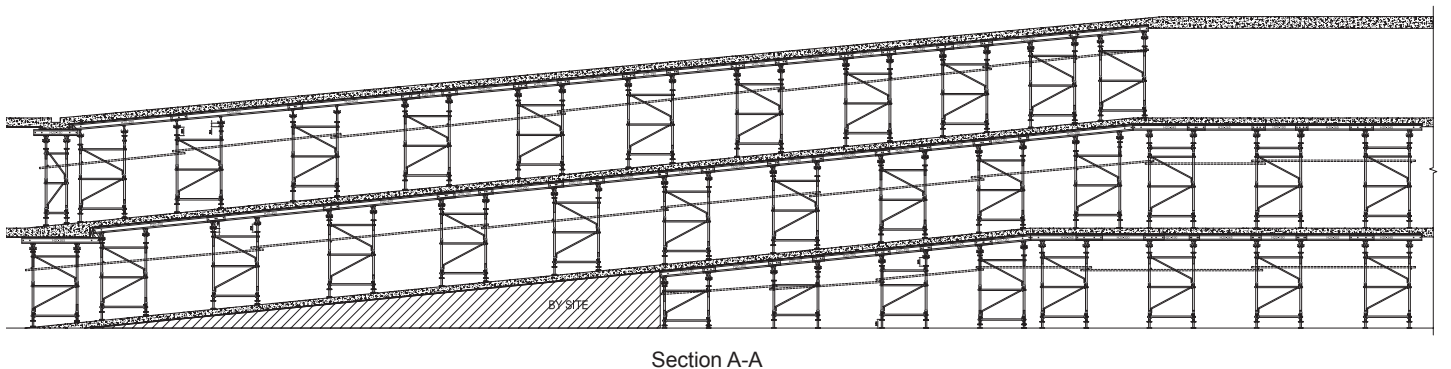
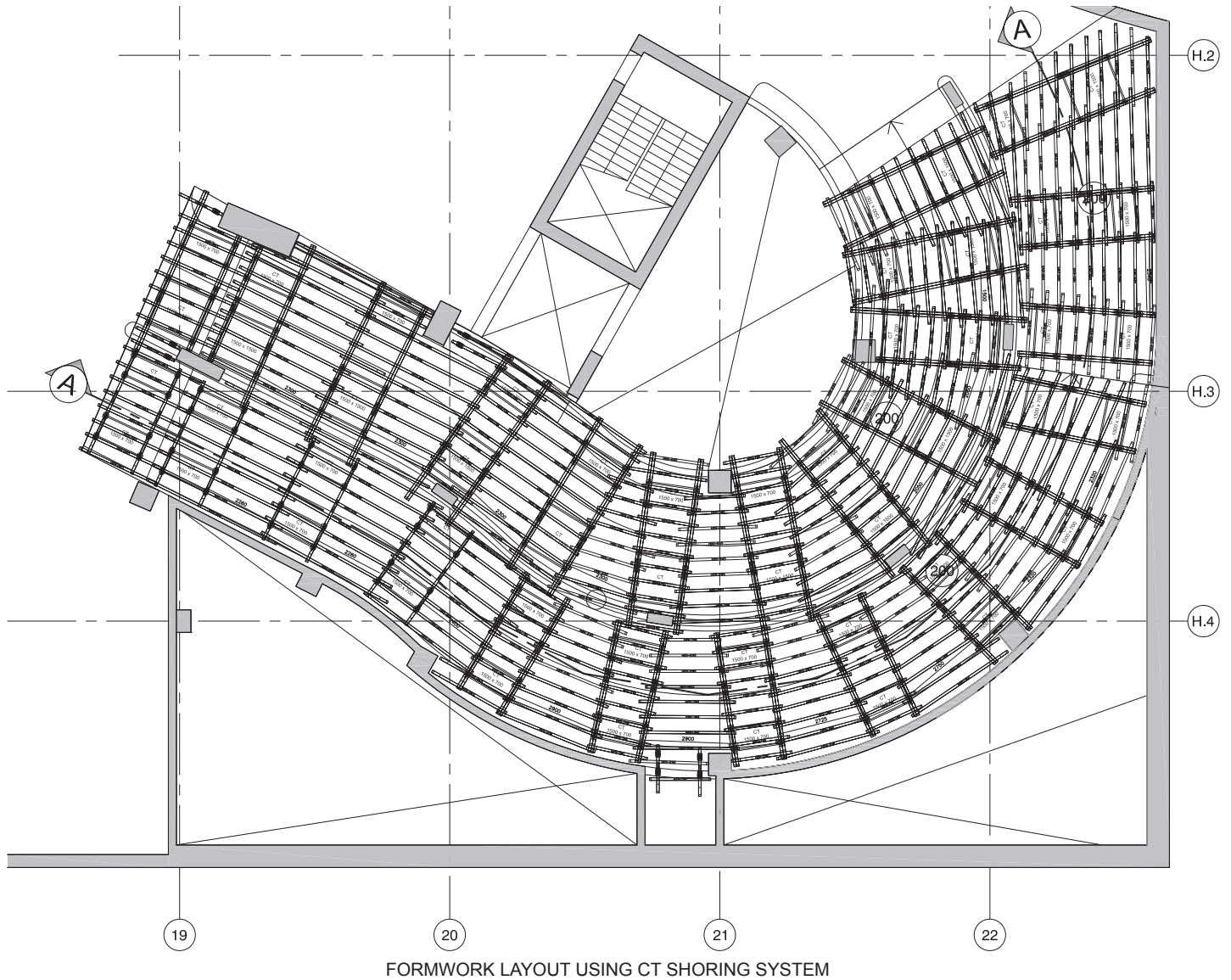

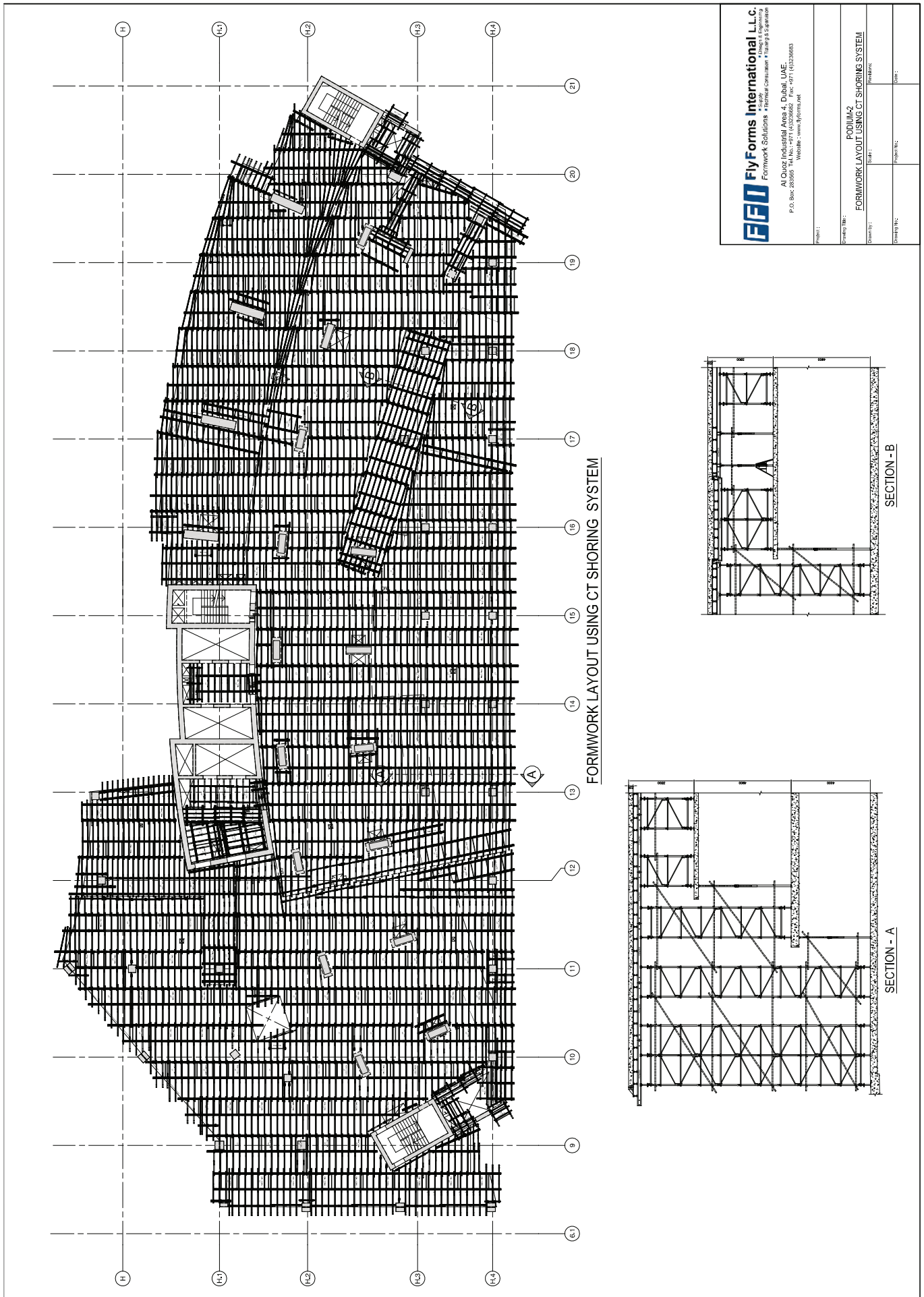

 FlyForms International L.L.C. Formwork Solutions • Design & Engineering Al Quoz Industrial Area 4, Dubai, UAE. P.O. Box: 282895 Tel: No: +971 (0)2329683 Fax: +971 (0)2329683 Website: www.flyforms.net	
Project:	PODUM-2
Contract Ref:	FORMWORK LAYOUT USING CT SHORING SYSTEM
Quantity:	Sheet:
Drawing No:	Project No:
	Date:

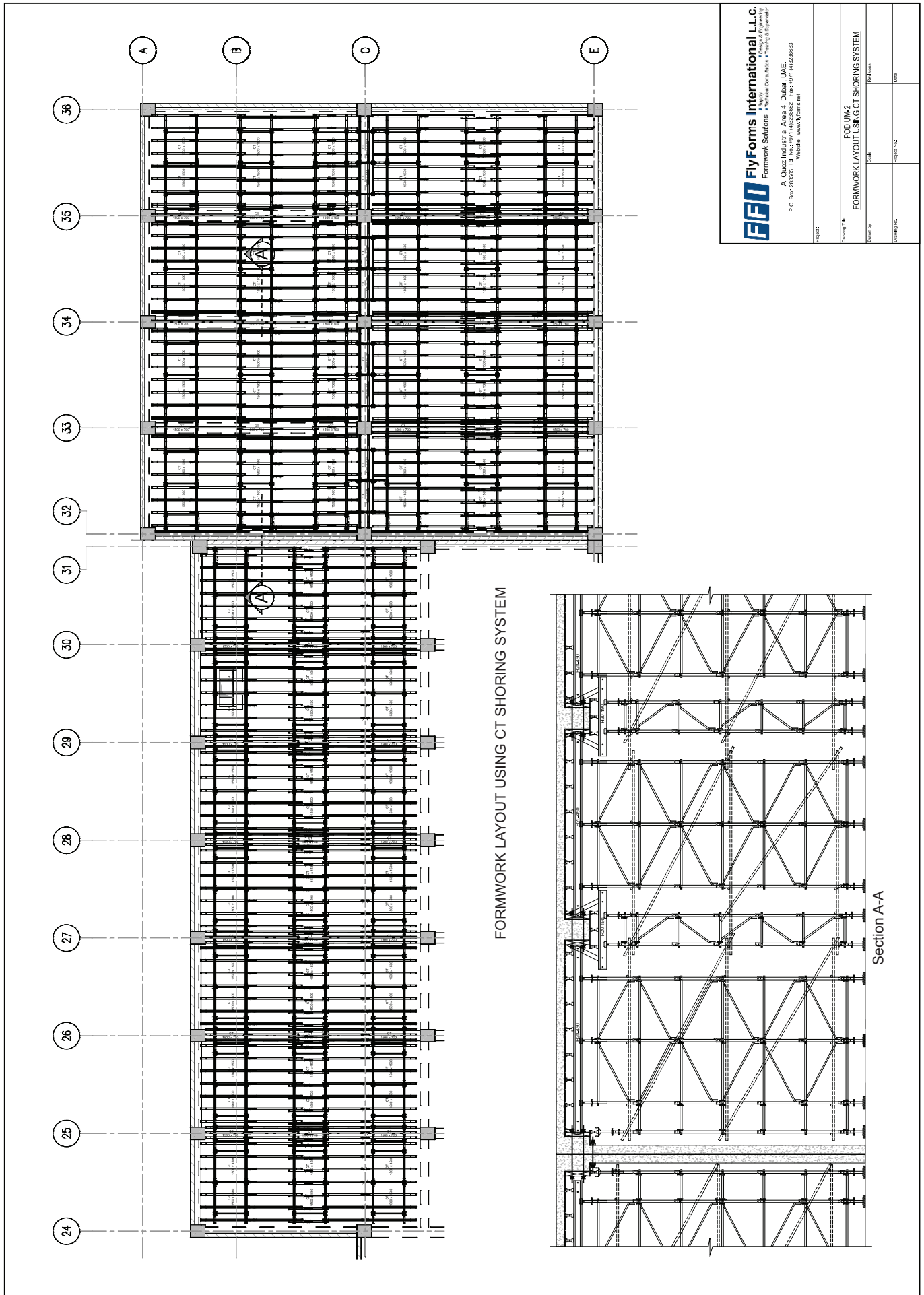

FFI FlyForms International L.L.C.
 Formwork Solutions • Safety • Quality • Efficiency • Innovation • Training & Supervision
 Al Quoz Industrial Area 4, Dubai, UAE.
 P.O. Box: 283595 Tel: No: +971 (0)3336882 Fax: +971 (0)3336883
 Website: www.flyform.net

PROJECT:	PODILUM-2
Drawing No.:	FORMWORK LAYOUT USING CT SHORING SYSTEM
Scale:	1:1
Project No.:	
Issue:	

FFI FlyForms International L.L.C. (Dubai)

Al Quoz – Industrial Area 4
P.O.Box 283565, Dubai, U.A.E
Tel. No. : +971 (4) 32 36 682
Fax. No. : +971 (4) 32 36 683
E-mail : Info@flyforms.net
Web : www.flyforms.net

FFI FlyForms International L.L.C. (Qatar)

Aziziya Commercial Complex
Aziziya Commercial Street - 424
P.O. Box : 16502 Doha, Qatar
Tel. No. : +974 - 4465 9766
Fax. No. : +974 - 4456 7250
E-mail : Info@flyforms.net
Web : www.flyforms.net

All Rights Reserved For Flyforms International L.L.C.

All material and information provided on this document unless specifically noted otherwise, is copyrighted material owned by flyforms international L.L.C.

Any individual or company making unauthorized usage and copies of FFI material will be subjected to the penalties as per the U.A.E law and regulation

